

A STUDY TO IDENTIFY POTENTIAL USES FOR UNWANTED CATCHES LANDED INTO IRELAND UNDER THE LANDING OBLIGATION

IRISH OBSERVER NETWORK LTD. AND MATIS LTD.

AUTHORS:

MIKE FITZPATRICK, JÓNAS R. VIÐARSSON AND MARVIN I. EINARSSON

May, 2018

THIS STUDY WAS CARRIED OUT WITH FUNDING FROM BORD IASCAIGH MHARA (B.I.M.) UNDER THE EUROPEAN
MARITIME AND FISHERIES FUND (EMFF).

irish | observer | net



CONTENTS

| | |
|---|-----------|
| LIST OF ABBREVIATIONS..... | 4 |
| EXECUTIVE SUMMARY..... | 5 |
| SECTION 1: REVIEW OF POTENTIAL USES FOR UNWANTED CATCHES..... | 10 |
| CURRENT AND POTENTIAL USES OF UNWANTED CATCHES | 11 |
| FOOD | 12 |
| BIO – PRODUCTS | 14 |
| FEED | 18 |
| INDUSTRIAL USES | 20 |
| ENERGY | 20 |
| AGRONOMIC USES | 20 |
| CURRENT UTILIZATION OF UNWANTED CATCHES IN NORWAY AND ICELAND | 22 |
| NORWAY | 22 |
| ICELAND | 26 |
| COUNTRIES THAT ARE ADAPTING TO THE EUROPEAN LANDING OBLIGATION | 34 |
| DENMARK | 34 |
| FRANCE | 36 |
| SPAIN – BASQUE COUNTRY | 37 |
| INTERVIEWS WITH STAKEHOLDERS | 38 |
| ONBOARD HANDLING OF UUC | 39 |
| SAFETY AND QUALITY CRITERIA FOR UUC | 41 |
| HUMAN CONSUMPTION | 41 |
| ANIMAL FEED | 43 |
| OTHER USES | 46 |
| SUMMARY OF SAFETY AND QUALITY CRITERIA’S RELEVANT FOR UUC | 46 |
| SECTION 2: IDENTIFYING BEST USES FOR UNWANTED CATCHES IN AN IRISH CONTEXT .. | 48 |
| BREAKDOWN OF IRISH LANDINGS AND DISCARDS OF DEMERSAL TAC SPECIES | 48 |
| BREAKDOWN OF IRISH LANDINGS AND DISCARDS OF PELAGIC TAC SPECIES | 58 |
| INTERVIEWS/PORT VISITS | 61 |
| OVERALL IMPLICATIONS OF THE LANDING OBLIGATION: | 62 |
| GENERAL ECONOMIC ISSUES: | 62 |
| INFRASTRUCTURAL ISSUES | 62 |
| FISHMEAL | 63 |
| PET FOOD | 64 |
| BAIT MARKET | 65 |
| NEW UTILISATION OPTIONS MENTIONED BUT NOT CURRENTLY USED. | 65 |
| OTHER COMMENTS FROM INTERVIEWEES. | 66 |



| | |
|---|-----------|
| SECTION 3: COST EFFECTIVENESS ANALYSIS OF POTENTIAL USES FOR UUC | 67 |
| CURRENTLY AVAILABLE OPTIONS | 68 |
| OPTIONS REQUIRING MORE SIGNIFICANT INVESTMENT OR LONGER TIME SCALES | 72 |
| SCENARIOS | 76 |
| CONSEQUENCES OF REDUCTION IN VOLUMES OF DISCARDS. | 76 |
| COST REDUCTION | 77 |
| CONCLUSIONS | 79 |
| REFERENCES | 82 |



LIST OF ABBREVIATIONS

| | |
|-------|---|
| CFP | Common Fisheries Policy |
| DCF | Data Collection Framework |
| EMFF | European Maritime and Fisheries Fund |
| FPC | Fish Protein Concentrate |
| FPH | Fish Protein Hydrolysed |
| ITQ | Individual Transferable Quota |
| LO | Landing Obligation |
| MCRS | Minimum Conservation Reference Size |
| MLS | Minimum Landing Size |
| OTB | Bottom Otter Trawl |
| PTB | Bottom Pair Trawl |
| PUFA | Polyunsaturated fatty acids |
| RFID | Radio Frequency Identification |
| RRM | Rest Raw Materials |
| STECF | (EU) Scientific, Technical and Economic Committee for Fisheries |
| UUC | Unwanted Unavoidable Catches |



EXECUTIVE SUMMARY

The overall aim of this report is to assess likely volumes of unwanted catches which may be landed into Ireland under the Landing Obligation (LO), to identify potential uses for those catches and to carry out a cost-effectiveness/feasibility analysis to establish which of these options have the most potential to deliver an economic return to fishermen. This overall objective was approached through a number of sub tasks:

- A global review of potential uses for unwanted catches based on all available literature, interviews and case studies.
- An assessment of likely volumes of unwanted catches which would be landed in Irish ports under a landing obligation. This was done by analysing and cross referencing landings and discard databases with port and species breakdowns to evaluate which fishing gears generate the most discards and the most likely landing locations as well as quantities.
- Infrastructural and economic factors were analysed through interviews with key personnel in the identified ports who would have responsibility for handling the unwanted catches. Interviews and meetings were held with sales agents, processing companies, bait distributors, industry reps, fish meal, fish protein and pet food plant managers in order to get their views on likely volumes, constraining factors, infrastructural requirements, market and other economic issues.
- The cost and revenue data collected during the interviews was used to conduct a cost effectiveness analysis of the most promising utilisation options. The cost effectiveness analysis was based in the first place on the economic return to fishermen rather than on points further along the value chain (e.g. return to processors).
- Scenarios were developed accounting for a number of future uncertainties such as changes in expected volumes due to improvements in selectivity or changes in the cost base due to factors such as new processing options and the impact of these scenarios on the cost effectiveness analysis was analysed.
- Finally the utilisation options with the greatest potential to resolve challenges posed by the LO in Ireland were identified. Recommendations are made about which uses have most potential, based on likely volumes and their distribution, infrastructural requirements, economic incentives and likely barriers.

Data sources for the report included the EU Scientific, Technical and Economic Committee for Fisheries (STECF) database of European fisheries landings and discards (<https://stecf.jrc.ec.europa.eu/dd/effort/graphs-annex>) and official Irish landings figures data and port based breakdown of landings as reported under the Data Collection Framework (DCF).

Information from published deliverables of the EU funded Horizon 2020 research project DiscardLess was also used, particularly in Section 1.

The key points arising from the above tasks are:

Potential volumes of unwanted catches could be significant. The table below shows a total estimate of unwanted catches (i.e. catches below the Minimum Conservation Reference Size: MCRS) of 6 key species of 4571 tonnes which could be landed by the Irish fleet. This table is restricted to key species for which significant quantities of unwanted catch may be landed.

* It must be stressed that due to the numerous uncertainties which could affect implementation of the LO as well as uncertainties within the estimation process, the figures reported here should be treated only as indicators of potential volumes of below MCRS fish which may be landed.

| Irish vessels, All fishing gears, ICES Areas VI & VII (excl VIId) | | | |
|---|-------------------|------------------|-------------------------|
| Annual average 2014-16 | | | |
| Species | Discards (tonnes) | % discards <MCRS | Discards <MCRS (tonnes) |
| Whiting | 3,686 | 39 | 1,438 |
| Haddock | 2,898 | 49 | 1,420 |
| Nephrops | 1,573 | 48 | 752 |
| Hake | 1,016 | 46 | 467 |
| Plaice | 612 | 44 | 269 |
| Cod | 336 | 67 | 225 |
| Total | 10,121 | 45 | 4,571 |

Regarding utilisation options there are no “magic bullet” solutions that can produce high economic returns to fishermen for size classes of fish that previously had no economic value. Returns will be in most cases a fraction of the value that smaller grades of above minimum size fish can achieve.

One of the implications of this finding of low economic value is that concerns are unfounded that the LO will result in the targeting of undersize and juvenile fish by requiring fishermen to land small fish. At least in the case of Ireland there is no possibility of this occurring under current conditions. Unfortunately, this also implies that there are not significant economic incentives to comply with the LO in the sense that compliance means the landing of small fish. Quota Uplift, the raising of quotas to account for fish that was previously discarded, should address at least some of this economic loss issue.

The second implication and the flipside of the first, is that there is a huge incentive to fish more selectively and, as far as possible to utilise the quota available in the most economically rational manner. The landing of below MCRS fish will lead to the loss of a large part of the future economic



value in those fish. The values we have calculated for currently available options show that 1 tonne of above MCRS fish is worth at least 6 times the value of 1 tonne of below MCRS fish.

Selectivity improvements alone cannot resolve all LO issues however and some residual unwanted catches will always be an issue in most demersal fisheries. In such cases the best current utilisation option appears to be the pot fishery bait market. When averaging between fresh and frozen supplies to this market a value of €100 to €120 per tonne could be returned to the fisherman for below MCRS fish landed. While significant investment in advanced equipment is not required for this option the main infrastructural constraint here is access to refrigerated and frozen storage. This issue has been successfully addressed by a number of co-ops and sales agents who have received EMFF funding from BIM to improve storage infrastructure. Even in upgraded facilities at certain times when large volumes of commercial landings are present there would still be competition for space in refrigerated storage.

The next best currently available utilisation options are fishmeal, which can essentially take an unlimited supply, and pet food that can take more limited quantities. Both options would deliver a price per tonne to fishermen of approximately €50 per tonne. This highlights the fact that the price differential in demersal fish between small size grades of fish sold on the fresh market and fishmeal is far higher than it is for pelagic fish which is why the fishmeal option is only used occasionally for demersal fish. The prices achievable in the fishmeal option are essentially fixed as fishmeal is a global commodity and significant improvements on that price are highly unlikely.

In the pet food option there may be opportunities to improve prices to a level above that outlined in our initial analysis. Conversations with pet food company operators and Enterprise Ireland experts in the area have highlighted that there is a growing market for high quality niche pet food products from whole fish or fish-based ingredients. In common with any other potentially promising options the requirement would be for a reasonably stable and significant supply of good quality fish with as little mixing of species as possible. The high value pet food market is an option that is worth exploring further.

A potential option, which is being discussed throughout Europe as a potential utilisation solution, is the use of small silage units to stabilise unwanted catches either at sea or ashore before distributing the product to fishmeal plants or other buyers. The difficulty with this option is that it does not add significant value to the product without further concentration and concentration requires more significant investment in equipment. The main advantage of the basic silage process is that it prevents further degradation of the product and allows for the accumulation of silage until a full transport load is ready and thereby reduces transport costs. A network of regional silage units, partly funded by EMFF or other funding, with a partnership arrangement for transport with a fishmeal plant or other buyer and fed by a significant supply of raw material would have some potential to reduce costs and deliver a reasonable return to fishermen.



In the medium term there are a number of options that would require more significant investment but could potentially deliver higher value products. A common problem across almost all of these options is that there is a conflict between the investments required, their high supply volume nature, and the policy goal of the LO, which is to reduce the supply of undersized fish. The fact that to date only very small volumes of below MCRS catches have been landed throughout Europe adds to the unattractive nature of these options for investors, at least currently. One exception to this is the possibility that a supply of gadoid fish could potentially be block frozen and processed through the new fish protein plant in the North West of the country. The technical details and economic viability of this would have to be worked out but it is an option worth exploring as potentially there could be a high value market available for the products of this process.

In the long term what should be aimed at, in line with the desired goal of the LO to reduce unwanted catches, is high value uses of smaller volumes of below MCRS fish which cannot be avoided. This calls into question any business plans and large infrastructural investments based solely on discards. Viable options would have to be established in conjunction with existing processing operations and existing supply lines of processing waste or low value commercial grades of fish.

To summarise in order to successfully add value to unwanted catches in the longer term it appears that most if not all of the following criteria should be met:

- Prospective operators would have to be confident that a reasonable supply of smaller fish will be available in the first place.
- Prospective plants should ideally be in, or at least in close proximity to, a fishing port where significant landings will occur as protein degradation in fish occurs quickly.
- Synergies with other fish processing activities are essential in particular regarding energy recycling and labour.
- A long-term approach will have to be taken by any prospective operator. Experiences from Norway and Iceland have shown that over time significant economic activity by companies specialising in high-value, niche products from viscera or other parts of fish will not appear overnight but develop over time.
- The financial clout and long-term commitment required means that either a large co-operative or consortium would be necessary in order to sustain the enterprise.
- It will be necessary to fully exploit high value niche markets for all product streams in order to get the most value from the raw material. For example, a fish protein (FPH) operation could target pharmaceutical products or human functional foods at the higher level, performance proteins for high-end animal feed at the middle level and high-quality fertiliser at the lower level. A successful example of this approach is the case of Celtic Sea Minerals,



based in Castletownbere, which has gradually, through investment in R&D, increased the niche value of its products over time.

- Achieving this will require significant technical and marketing expertise and a commitment to R&D.
- Companies in other countries with a history of bycatch and by-product utilisation have built up significant expertise in both the technical aspects of these processes and in the marketing of the final products so a partnership approach with such companies would be advisable.



SECTION 1: REVIEW OF POTENTIAL USES FOR UNWANTED CATCHES

The objective of this section of the report is to identify available alternatives when it comes to utilising unwanted fish catches and low value rest raw materials. The motivation for this work is the implementation of the Landing Obligation (LO) within the EU Common Fisheries Policy (CFP), which states that all catches must be landed and counted against quota once the obligation has been fully implemented. The LO also places restrictions on how undersized fish can be utilised i.e. fish under minimum conservation reference size (MCRS) cannot be used for direct human consumption.

There are a number of available alternatives for utilising these materials, all of which have their pros and cons, which are discussed in this report. The report draws upon experience from some of the countries that have been operating within a discard ban policy for a long time and have subsequently developed methods for utilising materials that would otherwise have been discarded.

This section of the report also provides insights into some of the challenges fishermen and processors have experienced when attempting to follow the discard bans in countries that have such bans in place. The authors of the report have as well interviewed fishermen and managers on the subject, which gives some insight into how the sector in selected countries accept discard bans/Landing obligations.

This section of the report will serve as background information for Section 2 when trying to identify potential uses for unwanted catches landed into Ireland under the Landing Obligation.

CURRENT AND POTENTIAL USES OF UNWANTED CATCHES

The available alternatives for utilisation of excess rest raw materials (RRM) and unwanted unavoidable catches (UUC) can be broken into six main categories, which are shown in Figure 1. These range from being low-tech production of well-established products, to highly innovative high-tech production of novel products.

Figure 1.1: Marine products produced out of RRM and UUC

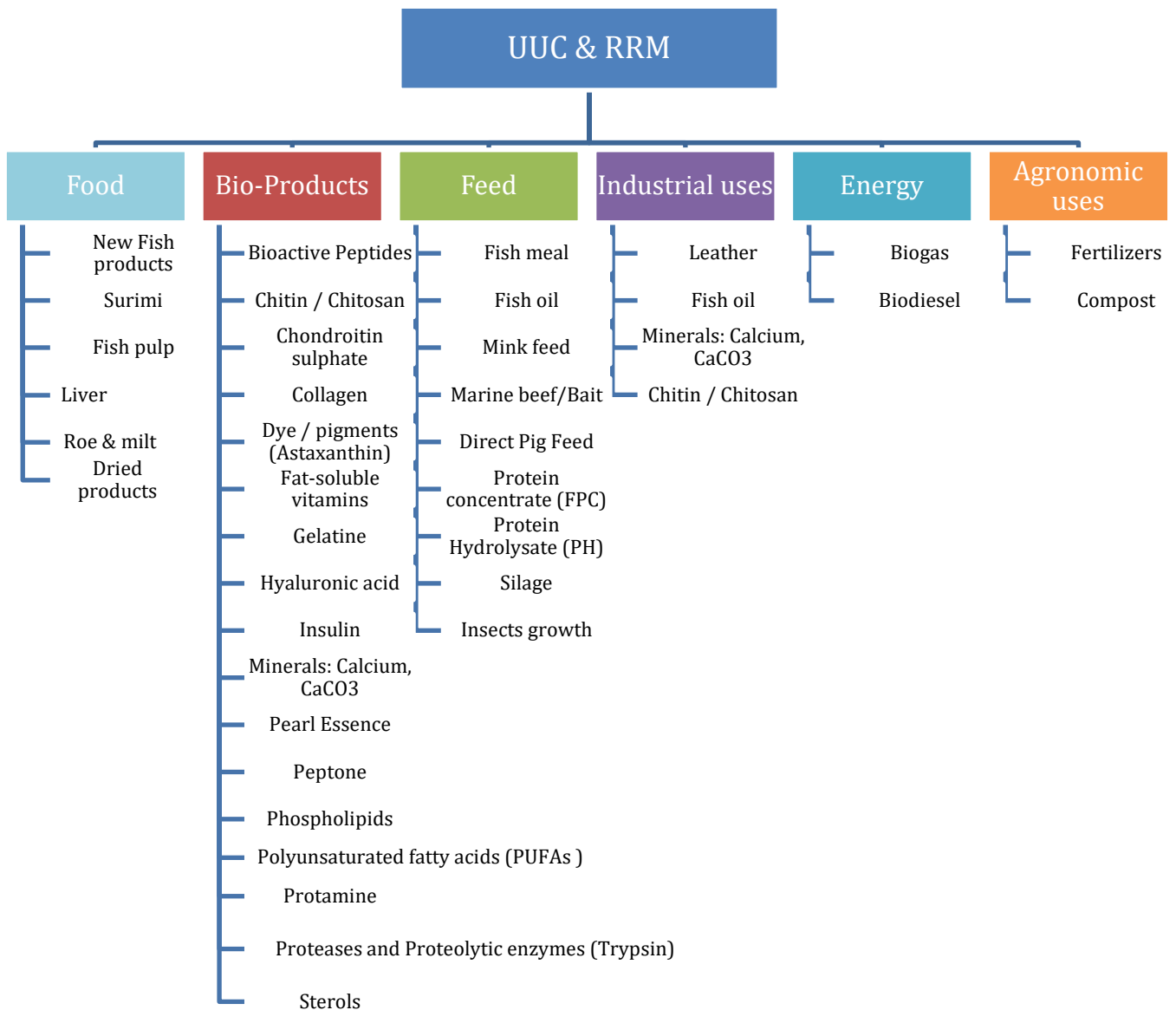

FOOD

There are considerable opportunities regarding development of new fish products, such as fish fingers, burgers, flavourings, sauces, canned fish products, protein additives and especially for products made out of minced fish muscles. Mince can be processed from cut-offs, other RRM such as heads and backbones, from UUC or even fish under minimum conservation reference size (MCRS) if no legal restrictions stand in the way.

Minced fish products: such as fish sausage, fish paste, hamburgers, fried minced fish along with pre-made fish dishes have gotten increased attention by consumers and authorities as low commercial value fish source that could increase fish consumption. These minced fish products are already well known in Europe, they are either sold fresh or frozen. Nowadays, these minced fish products mainly consist of whitefish species such as cod, haddock, whiting, Alaskan pollock for example and are often extracted from cut-offs, fillets of low quality (e.g. due to gaping), backbones/frames, juvenile catches and other catches of low commercial value. Few experiments have however recently been conducted with other species such as horse mackerel and blue whiting to make fresh fish burgers. The results have been positive as one study showed excellent sensory properties and good suitability for other culinary recipes (fish fillings, fish balls) due to their light fishy flavour, taste and textural properties (chewiness and juiciness) after cooking. In the production process, the fish is de-heated and gutted, a mincer separates skin and bones from the muscle, the mince is mixed with vegetables or other ingredient and natural preservatives, it is then packaged with nitrogen for preservation purposes. The shelf life for these products is considered 7-9 days, at correct storage temperatures.





Figure 1.2: Fish burgers, fish fingers, surimi, tempura breaded cod and canned mackerel

Other products, such as fish based extrusion products are also an alternative to look into. These are expanded fish snacks, fish fingers and sticks, protein gels, surimi and surimi based products. One alternative that is gaining increased attention among NE-Atlantic processors is for example to make surimi from blue whiting, which has almost solely been used for fishmeal in the past.

New fish-products may also rely on other more traditional and modern technologies for producing fish products. Such as proteolyzed fish products which can be fermented fish products, semi-preserved fish products, fish silage and fish protein hydrolysate (FPH). Fish products that have undergone thermal treatment for ready-to-serve meal and canned products. Other processing methods to mention are freezing with forced-air, IQF (Individually Quickly Frozen), cryogenic system, CAS (Cells Alive System). Vacuum drying, irradiation, microwave, DIC (Instantaneous Pressure Drop), HP (static and dynamic High Pressure), pulsed Light, modified atmosphere packaging of seafoods, active packaging (antioxidant, antimicrobial).

Liver, roe & milt: By-products made from cod liver, roe and milt have become increasingly valuable in recent years. The freshest materials become high value premium products and the rest is sold in bulk or used in lesser valued products such as liver oil.



Figure 1.3: Liver, roe and milt

Dried fish products: There have traditionally been good markets for dried cod heads and fish frames in Africa, particularly in Nigeria, where these products are mostly boiled to make soup. Heads, frames and cut-offs that are left after processing of haddock, saithe, tusk and ling are also suitable, but heads and frames from more fatty fish species like wolffish and redfish are not applicable for drying. Figure 4 shows the end-product made out of cod.



Figure 1.4: Dried cod frame (bones) and head

The markets for these dried products have however been difficult in recent years, because of financial difficulties in Nigeria due to low oil prices (Nigeria’s main export product).

BIO – PRODUCTS

When UUC cannot be used for direct human consumption there are a number of available options for alternative use. Many of these alternatives are gaining increasing attention, which may lead to interesting products and increased revenues. Fishes contains a large number of biomolecules of high value that can be used in food, pharmaceuticals and cosmetics, as well as in the feed industry (pet-food, aquaculture and cattle).

Bioactive Peptides: come from the extensive hydrolysis of fish protein and contains mainly free amino acids di-, tri- and oligopeptides. These peptides present biological activities that make them valuable for pharmaceuticals, cosmetics, food- and feed products. Figure 5 shows peptide powder made out of collagen from cod skin.



Figure 1.5: Peptides made from cod skin - collagen and gelatine



Polyunsaturated fatty acids (PUFAs): come from the purification of fish oil, obtained from viscera or from fatty fishes, and are fats with more than one unsaturation's (double bonds) present in the chain. PUFAs includes important compounds such as essential fatty acids that are correlated with the cardiovascular health of humans.

Proteases and Proteolytic enzymes: extracted from by-products, especially viscera, that contain a large proportion of digestive enzymes including collagenases, trypsin, pepsin, chymotrypsin, elastase, and carboxylpeptidase. Proteolytic enzymes from fish catalyses the degradation of peptide bonds of proteins. They have specificity of action and in the case of those from fish they have activity at low temperature and pH. They play a key role in a wide variety of physiological processes, biotechnology, food processing and other industries.

Chondroitin sulphate: obtained by an enzymatic or chemical hydrolysis process to deproteinize the cartilage and successive purification phases from the skeleton of cartilaginous fish, sharks and rays. Chondroitin sulphate provides cartilage with its mechanical and elastic properties, and gives this tissue a large part of its resistance to compression. It is used as a dietary supplement with anti-inflammatory properties, as an aid against arthritis.

Fat-soluble vitamins: are obtained by solvent extraction of vitamins from fish oil. Vitamins are classified as either fat soluble (vitamins A, D, E and K) or water soluble (vitamins B and C), difference that determines how each vitamin acts within the body. Fish liver oil is rich in vitamins A and D that are used in pharma, cosmetic and food applications.

Minerals (Calcium, CaCO₃): is obtained from spines, flakes and fins of fish and shells of bivalve molluscs (mussels, clams etc.). It can be used as mineral supplement in nutraceutical market (for human or animals), as food ingredient.

Dye / pigments (Astaxanthin): is extracted mainly from crustacean shells. It is used as a pigment in aquaculture, in fish and crustaceans feeding.

Collagen: is obtained by an acid or basic treatment of spines, scales and skin. The amino acid content of collagen differs from other proteins because of their high content of proline and hydroxyproline. Collagen is widely used in pharmaceuticals, cosmetics and also as food supplement. Figure 6 shows some of the products made from collagen.



Figure 1.6: Collagen is used as ingredient in variety of products and is particularly popular in food supplements, pharmaceuticals and cosmetics

Gelatine: is obtained from the irreversible hydrolysis of the collagen. There are two main types of gelatines, Type A obtained from the acid hydrolysis procedure and Type B obtained from the alkaline hydrolysis procedure. Gelatines is used as gelling agent in pharmaceuticals, cosmetics and food. Fish gelatines are preferred for low temperature gelling needs. The world market for gelatine is extremely large, as it is used in variety of products, ranging from puddings to gummy bears; and face masks to capsules around pharmaceuticals, as shown in Figure 7.



Figure 1.7: Example of products that contain gelatine

Most of the gelatine produced in the world are made from terrestrial animals, but with increasing numbers of consumers that do not want to eat farmed animals the market for fish gelatine is becoming stronger. There are also large portions of consumers that do for example not want gelatine made from pigs (for religious reasons) or horses (for ethical reasons).

Sterols: steroids found in plants and animals can be obtained by extraction. Phytosterols have received much attention in the last decade because of their cholesterol-lowering properties and can be found in marine organisms in small quantities, as a dietary origin from phytoplankton. The major presence of phytosterols is observed in bivalves, due to phytoplankton food sources. Phytosterols are largely used in the food and beverage industry.



Insulin: extracted from various fish viscera. Insulin is a peptide hormone produced by beta cells of the pancreatic islets, and by the Brockmann body in some teleost fish. Insulin regulates the amount of glucose (sugar) in the blood and is required for the body to function normally, and is used for treating diabetes.

Protamine: purified mixture of simple proteins obtained from wild salmon sperm Protamine is a protein (Molecular weight around 4,000-5,000), which works to maintain and protects DNA from being damaged. It is used in pharma as a drug that reverses the anticoagulant effects of heparin by binding to it.

Hyaluronic acid: obtained by successive extraction and purification steps, it is a glycosaminoglycan present in skin, bones and joints. Its function is to give elasticity to these parts of the body. It is used in regenerative cosmetics of the skin and in injections in cosmetic surgery or in the recovery of injuries of joints.

Chitin / Chitosan: Chitin is obtained by deproteinization, discoloration of exoskeleton of arthropods. Chitosan is obtained by further deacetylation of chitin by chemical-enzymatic processes. It has uses such as chelating agent in the Water treatment, clarifier, thickener, fibre, film, chromatography column matrix, gas selective membrane, hypocholesterolemic agent, plant disease resistance promoter, anticancer agent, wound healing promoter and antimicrobial agent. It is used as a technological adjunct and is being tested for applications such as fruit preservation, wound dressings, cosmetics, artificial organs and pharmaceuticals. Chitosan made from the shells of prawns and lobsters is being used for pharmaceuticals and food supplements. All the shells available in Iceland are as example used by the company Primex for making pharmaceutical and food supplement products, shown in Figure 8.



Figure 1.8: Example of the products Primex produces from Chitin / Chitosan

Pearl Essence: is extracted from fish scales. Guanine is an iridescent substance that is found in the epidermal layer and scales. The suspension of guanine in a solvent is called "essence of pearls". It was used in cosmetics and paints.



Phospholipids: are extracted from fish oil by different procedures. Marine omega-3 phospholipids (n-3 PLs) are defined as PLs containing n-3 long-chain polyunsaturated fatty acids (PUFAs) derived from marine organisms. This makes them different from PLs derived from vegetable sources, since they do not contain long-chain n-3 PUFAs. Phospholipids are used as emulsifiers in the food industry, emollient in cosmetic, antibacterial or drug delivery system in pharma.

Squalene: extracted mainly from shark liver. Hydrocarbon compound, isoprenoid, intermediate in the synthesis of cholesterol, hormones and vitamin D. Used in cosmetics in moisturizers and in pharmacy or dietary supplements as an immune stimulator.

Peptones: produced by controlled enzymatic hydrolysis of proteins. Peptones are polypeptides formed during the enzymatic degradation of proteins. They are the main source of nitrogen in the organic medium for bacterial culture. They are used in the manufacture of culture media for microbiology and biotechnology (industrial fermentations).

FEED

The most common use of fish by-products in most countries is the production of fishmeal and fish oil, which is then mainly used for animal feeding. This alternative may also be of major interest for the processing of UUC as there are often infrastructures available that are generally close to harbours. However, many other valorisation options focused on animal feed can be considered.

Fish meal: obtained from any fish or fish by products, after a thermal process to coagulate the protein and separate the oil, fish meal is a brown powder rich in protein. The colour is affected by fish species, particle size, fat and moisture content. Fish meal is mainly used in animal feed. Aquaculture account for > 60 %, pigs 25 %, and poultry 8 %.

Fish oil: obtained in the same process as fish meal, fish oil is a liquid product composed mainly by fatty acids, high in unsaturated fatty acid, with variable amounts of phospholipids, glycerol ethers and wax esters. Fish oil has different uses that can vary in function of its composition. Approximately 80 % of the global fish oil production is used in aquaculture and about 13 % is destined to human consumption.

Mink feed: any fish or fish by-product can be used to feed mink for the fur industry (food regulation does not apply). This alternative is often used for products that cannot be used for anything else as food safety regulations do not have to be taken into consideration i.e. mink is not used for human consumption or for ingredients that become animal feed. Viscera, which contains digestive trace elements can therefore be used as mink feed. Figure 9 shows how viscera is block frozen in Icelandic fish processing plant and the blocks are then used for mink feed.



Figure 1.9: Frozen cut-offs from processing of whitefish and block frozen viscera

Marine Bait: discard species can be used as effective pot bait when targeting crabs and lobsters. The condition of the material is generally not important, which makes this a good alternative for low value materials that are difficult to preserve. Fish that is high in fat are usually considered good bait.

Fish Protein Concentrate (FPC): Dehydrated and grounded products, with a variable protein content, which may or may not taste and smell like fish, depending on the method of production used. This technology aims to achieve a stable product, with a protein concentration higher than that of fish muscle. The manufacture of this type of products allows for the use of species that are not accepted for direct human consumption, and of the waste from the fish processing industries. Used primarily for animal feed, but due to their high nutritional value, they can also be used for human consumption e.g. as food supplements or as a protein source in different foods.

Fish Protein Hydrolysate (FPH): Stable product with good functional properties and high nutritional value, prepared from the protein fraction of whole fish, by-products or processing waters thereof, by chemical or enzymatic hydrolysis. A product consisting of mixtures of amino acids and peptides of different sizes are obtained depending on the degree of hydrolysis carried out. It is used mainly in animal feed, but can also be used in the food industry as e.g. a flavouring or raw material for the elaboration of aromas.



Figure 1.10: Fish Protein Hydrolysate (FPH) powder

Silage: Liquid protein hydrolysate made from whole fish or from processed residues. The hydrolysis is carried out by endogenous proteolytic enzymes, located in the viscera and in the meat of the fish, under acidic conditions. Acid conditions limit the growth of degradative bacteria. It is used mainly as

a protein supplement in animal feed (cattle, poultry and aquaculture) and as a base for the production of fish sauce.

Insects meal and oil: obtained after the growing of insect over a fish substrate. Insect meal can be used for animal feed.

INDUSTRIAL USES

When the previous options are not available, for example due to legal constraints, quality of the raw materials or of the products, other technical uses may be considered, which are often considered as industrial uses such as:

Leather: is the cured and tanned skins of fish. Fish leather can be used to make a wide variety of items such as jewellery, accessories, belts, wallets, bags and in shoes. It can also be used for a much larger variety of crafts.

Low quality Fish oil: obtained in the fish meal production process can be used for industrial usage, such as solvent for painting, when it doesn't meet feed quality standards.

Low quality Minerals: Calcium, CaCO₃: is obtained from spines, flakes and fins of fish and shells of bivalve molluscs (mussels, clams, etc) and can be used as soil improver or mineral fertiliser.

Low quality Chitin / Chitosan: when the product is obtained with low purity or quality the chitosan may be used in less demanding uses such as biological systems, agricultural use or as filtering agent in water treatment.

ENERGY

Biogas: is produced through the anaerobic digestion (AD) of organic matter. This is a complex biological process in which anaerobic bacteria decompose organic matter in environments with little or no oxygen. The process produces biogas (55-65 % methane, 35-45 % carbon dioxide, and other) which is used as energetic source for heating or producing electricity. Also, a digested substrate is produced that can be used as fertilizer in agriculture.

Biodiesel: is obtained by a transesterification process of the fish oil. Biodiesel is later used in diesel engines as an energy source.

AGRONOMIC USES

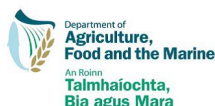



Compost/Fertilizers: obtained by an aerobic decomposition process carried out by the own microorganisms of the organic matter. Compost from fish usually consists of fish waste, saw dust, wood bark chips and is covered with leaf compost to make a compost pile. The compost is used for soil amendment or fertilizer. Also, fish protein hydrolysates can be used as fertilizer.

CURRENT UTILIZATION OF UNWANTED CATCHES IN NORWAY AND ICELAND

There are number of countries outside of EU that have been operating under a LO for considerable time. Iceland and Norway are one of those countries that have gradually improved their methodologies and approaches throughout the years and the experiences of these countries can therefore benefit others with the implementation of a LO. The following chapters address how the Norwegian and Icelandic industry have tackled the discard ban.

NORWAY

A discard ban has been in force in Norway since 1983 and is widely accepted within the Norwegian fishing industry and by the public. It was first implemented only on the most important species, but applies to all commercial species today and all vessels fishing in Norwegian waters. These species are managed under Individual Transferable Quotas (ITQs) and vessel group quotas. Catch is counted against quotas and all fishing activities that run the risk of over catching must stop when the quota is filled. Larger catches that exceed quotas or catches under MCRS can be landed without prosecution or penalties but the catch is confiscated by the sales organisations or the Directorate of Fisheries. The fishing company receives then 20% of the sales value, in order to cover landing costs and provide incentives for landing the catch. The sales organisations and the Directorate of Fisheries keep 80% for themselves. There are no restrictions on the use of juvenile/small fish and the first priority is therefore to use as much as possible for human consumption. The approach the Norwegians have applied in minimising the targeting of small fish are seasonal and emergency closures of fishing grounds with high proportions of small fish, as well as gear restrictions where selectivity mechanisms are required.



Norwegian demersal whitefish catches have amounted to around 800 thousand tonnes a year, for the past five years (Statistics Norway, 2017). By far the most important species are cod, saithe and haddock, representing over 90% of the catches. The share of each of these species can fluctuate slightly between years depending on stock size, but in 2016 cod accounted for 57% of the total whitefish demersal catches, saithe for 21% and haddock for 15%. The fisheries for these species are highly seasonal, particularly for cod and saithe, as over 60% of the cod catches are landed in the first four months of the year and 50% of the saithe catches are landed in the period between February and May. This uneven seasonal distribution has the effect that production needs to cope with extremely high throughput during the first four months of the year, making it difficult to allocate efforts on by-products and RRM that do not create similar value as the main products. According to recent estimations on the utilisation factor of whitefish in Norway, it is estimated that about 82% of the whitefish catches (in life weight) is utilised, in one way or another (Richardsen, Nystöyl, Strandheim, & Marthinussen, 2016). About 57% are used for primary products, meaning that 43% are RRM of which 48% are utilised. Compared to the pelagic- and aquaculture industries in Norway, this utilisation of RRM from whitefish is however relatively low. All RRM are for example utilised in the

pelagic industry and 91% in the aquaculture industry. The reason for this difference can to a some extent be traced back to the seasonal variability in catches of whitefish, high labour cost and lack of space and conditions for processing excess rest raw materials. But also, due to the fact that utilisation of whitefish RRM is mostly limited to boats that land fresh fish, while the majority of freezer trawlers discard their RRM i.e. viscera, heads and frames.

Boats landing fresh catches land the fish whole, usually with head-on, either gutted or un-gutted. This allows for increased utilisation of RRM on land, since the catch is processed on-shore where there are conditions for collecting and processing these secondary material streams. These fresh fish boats are in addition often fitted with equipment for gathering and processing liver, roe and milt onboard and or silage tanks that receive viscera offal's and sometimes heads.

The utilisation of RRM from both fishery and aquaculture industries has been towards production of silage, fishmeal and fish oil where only 12% of the RRM are intended for human consumption. This can be seen on Figure 11, which shows the distribution of the RRM going for different processing in 2015 (Richardsen, Nystöyl, Strandheim, & Marthinussen, 2016)

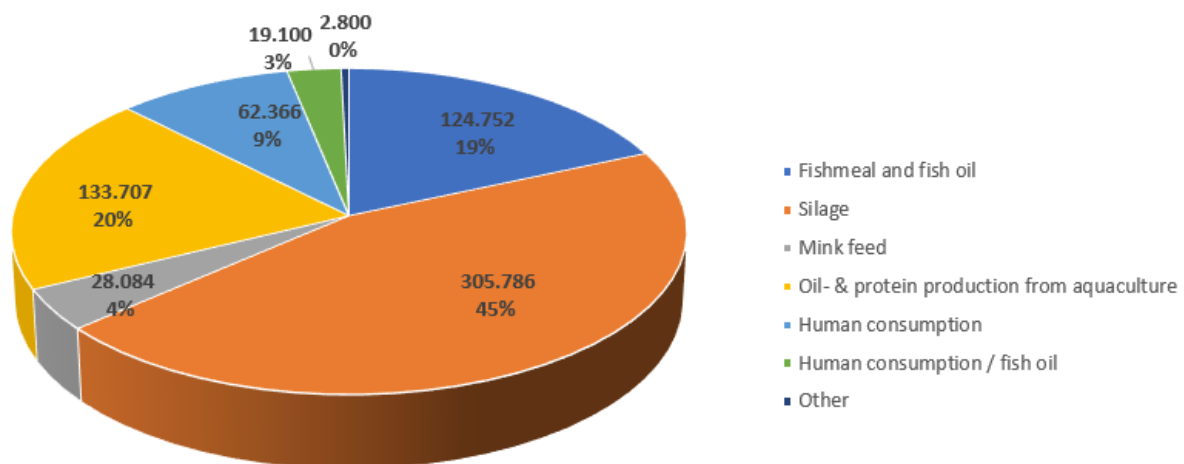

Figure 1.11: Allocated Unwanted Unavoidable Catches (UUC) and Rest Raw Materials (RRM) used for production of by-products in 2015 (in tonnes)

The trend in utilisation of UUC and RRM from whitefish and especially from cod has been moving towards production of products for human consumption, for example, by utilising cut-offs for mince production and for production of surimi or other foods for human consumption; instead of producing silage or fishmeal. The liver is for example now rather used for making canned liver for human consumption instead of producing fish oil for aquaculture, the roe are used for making caviar (Figure 12), the heads are dried for human consumption and more. There are however always parts such as viscera that are not ideal for human consumption and are therefore used in silage or fishmeal.



Figure 1.12: Norwegian caviar and salted roe made from cod roe

The Norwegian seafood industry produces large amount of silage, both from whitefish, pelagic and aquaculture industry. Silage is particularly relevant when it comes to processing and gathering of UUC and MCRS catches offshore when labour cost is high and when space is limited, for example in the vessels storage hold. The reason why Norway has become so big in silage and has managed to implement it on the wetfish fleet as well, can be explained by the fact that silage processing is relatively common all over Norway, due to its presence in the aquaculture industry. This makes easier access for whitefish operators to the silage facilities to land their RRM or their pre-made silage all year around. The leading company in the processing of silage in Norway is Hardafor AS. They produce fish silage from aquaculture species, pelagic and whitefish as well as producing and selling equipment for production of silage; offering ready to install solutions for the global market. They run their own production facilities in nine locations in Norway, Denmark and Faroe Island. They also run five specially equipped silage transportation tanker vessels and four trucks that can collect silage from all across Norway and even from abroad. They also buy in silage from smaller producers.

Silage is relatively cheap product when sold directly as mink-, livestock feed or directly into a fishmeal factory as a raw material. However, more valuable products are being made out of the silage such as fish protein hydrolysate (FPH) and fish protein concentrate (FPC). FPH is mostly used as an additive into both aquaculture and livestock feed. The production process is slightly different from the silage process as enzymes are added along with the acid during the degradation process to make it possible to extract specific peptides and ammonia acids. Along with that, the silage is de-oiled and bones are sieved out, a description of that can be seen on Figure 13. FPH is also sold as health supplement for human consumption and nutraceuticals. It has also been shown that FPH can serve as a disease resistance for aquaculture species and as stimulator for their immune system and can increase feed consumption as well, which makes FPH particularly interesting option as an aquaculture feed additive (Shahidi & Barrow, 2007). Almost 15 thousand tons of FPH were produced in Norway 2015 which primarily went into aquaculture feed.

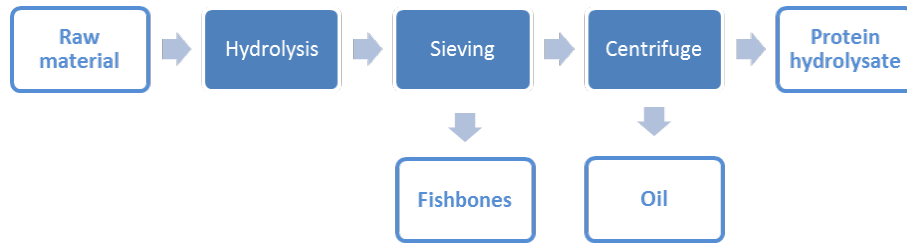

Figure 1.13: Simplified schema of protein hydrolysate process

FPC is a much simpler production than FPH, as it is basically a de-oiled and thickened silage that has gone through oil separation and thickening in evaporators. Figure 14 shows the main steps in the production of FPC. Despite FPC not being as valuable as FPH, fish oil is produced along with the FPC which increases the margin. Fish protein concentrate is mostly used for aquaculture-, livestock- and fur breeding feed.

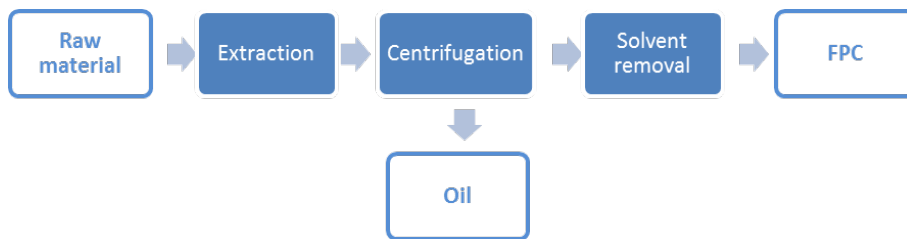

Figure 1.14: Simplified schema of fish protein concentrate process

In 2015 a total of 77 thousand tonnes of FPC were produced in Norway from UUC and RRM. Figure 15 shows the main product categories and production volumes, in tonnes, derived from UUC and RRM in 2015 (Richardsen, Nystöyl, Strandheim, & Marthinussen, 2016).

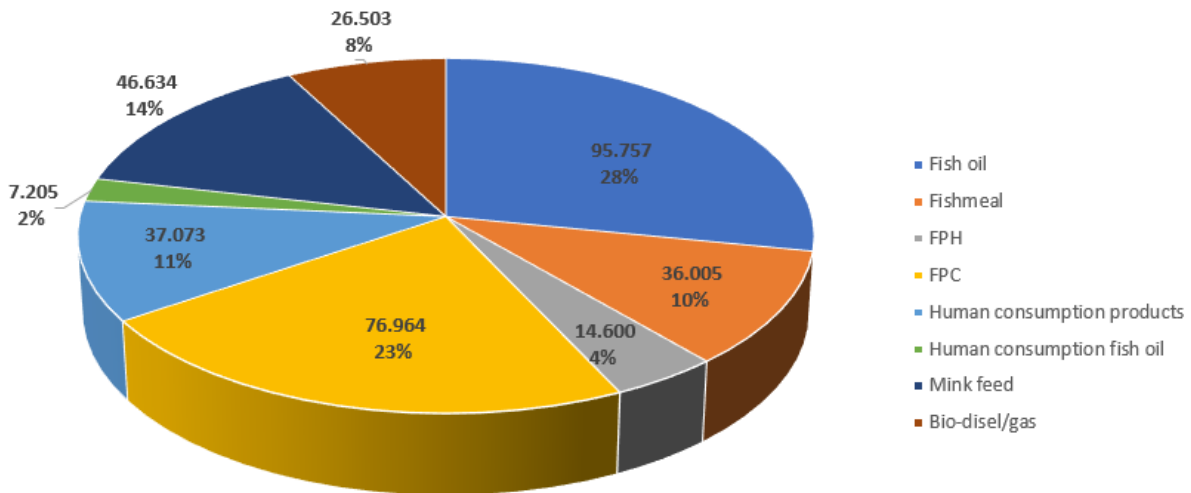

Figure 1.15: Products made from Unwanted Unavoidable Catches (UUC) and Rest Raw Materials (RRM) in 2015, in tonnes

It is difficult to estimate the contribution of the discard ban to improving selective fishing practises and increasing utilisation of UUC and RRM in Norwegian fisheries. The management system has at least been successful at reducing the capture of juvenile fish (Graham, Ferro, Karp, & MacMullen, 2007). But some species, such as the Norwegian coastal cod, are though still struggling due to low stock size and overfishing (ICES, 2017). The fact that all catches are utilised for making valuable products, along with strict surveillance and wide scale social opposition against discarding, has contributed to making discarding a minor issue in Norwegian fisheries.

ICELAND

A number of measures have been implemented over the past three decades with the aim of reducing discards in the Icelandic groundfish fishery. In 1977 the landing of all catch of six main commercial fish species (cod, haddock, saithe, golden redfish, plaice and Greenland halibut) was made mandatory by law, and, thus, discards prohibited for the species in question (EC, 2007). Then in 1984, along with the introduction of the ITQ-system in the demersal fisheries, some restrictive measures regarding minimum landings size were abolished. Prohibitions of discarding were however retained. At the same time, it was permitted to land and retain “undersized” fish up to a certain percentage of each landing without that volume being counted against the vessel’s annual quota. The purpose of this stipulation was to provide further incentives against discarding. The particulars of these regulations have been subject to numerous changes in subsequent years. In 1986, the discard ban was extended to cover catches of all ITQ-regulated species and in 1996 it became a part of the



Icelandic fisheries management legislation that all fish caught, irrespective of species or size, should be landed, and discards of any kind thereby prohibited.



The discard ban is generally accepted by the fisheries in Iceland and there is a wide acceptance as well for it amongst the public. The Icelandic fishery provides an example of where LO has been in effect for decades and where the success of the implementation can be studied to give other fisheries ideas on what to proceed with implementation and what to avoid. Discards today are minor, but that is the results of a long process where many variable factors have contributed to a successful development. The individual transferable quota (ITQ) system, integration of the value chains, consolidation in the industry and negative public opinion of discards play an important role, but a key factor is also that all catches are used for producing as much value as possible; there are no constraints on the use of for example undersized fish.

One of the advantages of the Icelandic discard ban is the many built in flexibilities that create incentives for landing all catches. One of those is a regulation that refers to fisheries being able to transfer up to 5% of its quota between years. This creates incentives to land excess catches legally and deduct it from the quota that would otherwise be intended for next year. The fisheries may also choose to land the excess catches or UUC without deducting it from quota, however, as in Norway that means they can only receive 20% of the revenue where the rest 80% goes to research funds where this 20% of the sales value is only intended to cover the landing cost (Directorate of fisheries, 2017a). Regarding catches that are under minimum conservation reference size (MCRS), landings can be counted 50% against quota creating incentive to land these catches. The MCRS catches are moreover accepted for human consumption which increases its value. In addition, larger overruns or large amount of non-target catches can be solved by purchasing additional quota.

The Icelandic fishery is different from other fisheries in many ways. One important factor that needs to be considered is the extensive consolidation and optimisation that has occurred over the last 20-30 years in the sector. These are side effects from the Individual Transferable Quota (ITQ) system where the quota has been aggregating on fewer hands. As an example, in 1992 ten of the largest quota holders owned 24% of the quota, and in 2017 the share of the ten largest had risen to 50% (Islandsbanki, 2016) (Directorate of Fisheries, 2017b). The share of the twenty largest quota holders today is 70%. This may have simplified the implementation of a discard ban, since much fewer stakeholders are involved. Fishery companies have been growing larger and individual and self-employed companies that operate only one boat are slowly disappearing. The companies are not only becoming bigger, but have much larger funds for investing in new technology and are in better position to develop innovative products.

Directorate of Fisheries holds an accessible database on annual landings of catches and landings of MCRS^{1*} catches. When discards are examined, these data are used where the amount of landed catch is evaluated in context with MCRS landings and population size. This is done by examining the ratios between MCRS and target catches and evaluate them with expected percentage of juvenile fishes in the stock to determine discard rates. This ratio is examined by measuring and analysing the stock sizes with regards to its age and size distribution. According to the Marine & freshwater Research Institute, haddock discard rates were 0.64% in 2015, whilst cod discard rates were 2.13%. Figure 16 shows the estimated discards in tonnes and discard rates for cod and haddock 2001-2015 (Sigurðsson, o.fl., 2016).

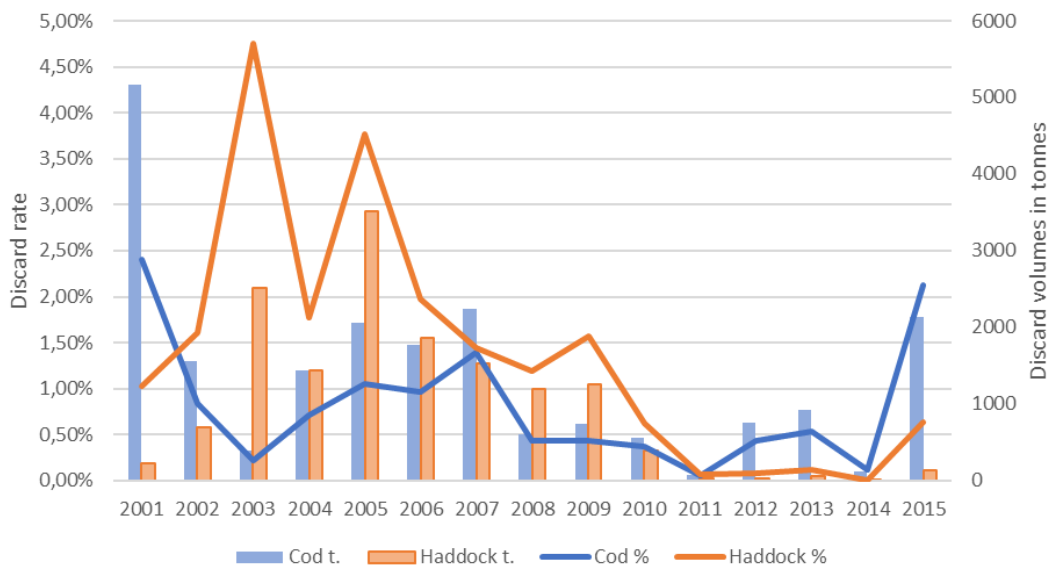

Figure 1.16 Estimated amount of discarded cod and haddock in Icelandic waters from 2011-2015

The reliability of these estimations may however be questioned, but there is a general belief amongst the industry, researchers and stakeholders that these estimations are relatively reliable. The fact though remains that discarding is illegal and estimations that are not able to rely on discard reporting from fishermen will always be subjected to questioning on reliability.

The Icelandic fishery has developed in such a way that today there are not really any catches that can be defined as UUC. This is however a development that has taken thirty years to gradually change. When the discard ban was first implemented in the Icelandic fishery there were significant discards in place, but with a number of concurrent actions and a change in mentality the sector has progressed so that today all catches are regarded as raw material for valuable products. The ITQ system has probably played the most important part in this progress, as incentives for discarding have been

^{1*} These are not actual MCRS, as such definition is not used in the Icelandic fishery. What this is in reality is juvenile, undersized fish (IS smáfiskur) which is defined in cm for all commercial species.



removed and efforts placed on developing products from all catches. The results are that today there are basically no unwanted catches in Icelandic waters.

The Icelandic Industry has many opportunities when comes to utilising UUC and MCRS catches since no legal restrictions are set regarding human consumption. The trend with MCRS catches has been towards bulk freezing for foreign markets, filleting & freezing or drying. Low value fish fillets from MCRS catches are for example widely available in Icelandic retail stores. Figure 17 shows frozen cod nuggets made from MCRS that are available in Icelandic retail stores.

Figure 1.17: Cod nuggets made from undersized fish



UUC species that have little commercial value are commonly dried whole (gutted), these are species such as starry ray, dab, megrim, flounder and even gurnard. The drying was traditionally performed outside, but has been moving towards indoor mechanical drying in more controllable environment which results in much better and more stable end products. These products are then sold to foreign markets, mostly in Africa. A key component in this development is that the Icelandic Industry has access to unexpansive geothermal energy source to power the drying, so the production cost is relatively low.



Figure 1.18: dried starry ray

Figure 18 shows dried starry ray, which is a good example of UUC that previously would have been discarded, but is now considered valuable catch.

Regarding the current utilisation of UUC and RRM, the Icelandic case is slightly different from Norway. Silage production has for example not caught on in Iceland and the focus has been more towards production of more valuable products for human consumption and bio technical products. Other UUC and RRM that are not readily applicable for added value production are commonly frozen for mink feed. In essence it can be claimed that everything that is landed is utilized, there are however materials that are not landed, these are particularly viscera from fresh fish vessels and parts of the heads and frames from the processing vessels. This is though changing now, as vessels are being fitted with equipment that allows for collection and storage of these UUC and RRM. Regulations have also been changed, so that factory vessels are now obligated to land part of the cod heads.

This development indicates that the utilisation of RRM may increase in near future in Iceland, particularly on larger processing vessels. Smaller fishmeal plants have also been set-up around harbours in Iceland, they receive RRM from the aquaculture industry and from larger fish processing plants. This development may indicate that fishmeal production of RRM may increase in near future. Silage production is another interesting alternative that could work well with fishmeal production. There is though some opposition amongst the industry to try silage production, which is mostly contributed to some failed attempts in the 80's and 90's. Potential new markets within a growing aquaculture sector in Iceland for silage, FPC and FPH may however result in the industry trying this solution again.

Today production of innovative products for human consumption and high value bio technical ones is to a large extent limited to RRM from cod. An example of that are leather made from fish skins, pharmaceuticals and cosmetics made from bioactive compounds extracted from different parts of the cod (and other fish species), collagen made from fish skin, supplements and protein made from



different by-products, mineral supplements made from fish bones, enzyme extracted from viscera, skin and tissue repair patches made from fish skin, extracts from RRM made into powder or bouillon (i.e. for making soups and sauces), silage made from viscera used for animal feed or as fertiliser, swim bladder and milt. Despite previous utilisation being mostly limited to cod products the landscape is slowly changing towards utilisation of other fish species as the operators have started to realize the hidden value in RRM. Figure 19 and 20 show some examples of UUC and RRM that previously would have been discarded, but are now considered valuable products.





Figure 1.19: Example of products made from UUC and RRM



Figure 1.20: Dried Icelandic fish products intended for human consumption, fresh cod head served at Icelandic restaurant, chandelier made from cod, cod oil and omega-3 from pelagic species are all examples of product development where previously discarded materials are used.



COUNTRIES THAT ARE ADAPTING TO THE EUROPEAN LANDING OBLIGATION

Iceland and Norway have managed to tackle discarding in their fleet to a certain point. They have managed to reduce discards significantly and have found ways to utilise UUC and MCRS catches, as well as increasing utilisation of RRM. They have developed their own fishery policies with built-in concessions for landings of UUC and MCRS catches that are in addition allowed for human consumption. That is however something that does not apply to all countries that are operating under discard bans, and in particular the countries that are currently implementing the CFP LO. Those countries are facing greater challenges, in respect to regulations regarding human consumption, fish stock- and fleet composition. The following chapters discuss the present and previous circumstances in Denmark France and Spain before the discard ban was implemented. The selected areas are North Sea, Kattegat and Skagerrak (Danish part), English Channel (French part) and Bay of Biscay (Spanish part). This coverage highlights landing and discard statistics in selected fisheries and estimates potential landings of UUC of each species that will be landed under the new European LO in relevant ports. Discard ratios, species composition and seasonal variations.

DENMARK

Reported annual discards of the Danish fleet have varied from 27 to 47 thousand tonnes in recent years, representing 4-11 % discard rate, where Nephrops have accounted for ½ - ¾ of the discards. Other species with significant volumes of reported discards are dab, plaice, shrimp, cod and rays. Discards of dab are around three thousand tonnes a year and discards of the other four species are between one and two thousand tonnes a year, but discards of other species are much lower. Table 1.1 shows discards and landings by Danish vessels in 2014 (STECF, Håkansson, & Ulrich, 2015).

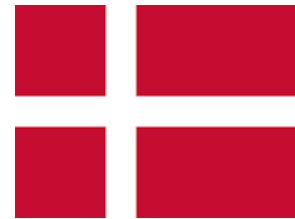

Table 1.1: Discards of Danish vessels in 2014 according to species

| Species | Discarded | | Landed | |
|-----------------------|---------------|---------------------|----------------|----------------------|
| | Tonnes | % of total discards | Tonnes | Species discard rate |
| Nephrops | 14,316 | 51.6 % | 3,472 | 80.5 % |
| Common Dab | 3,395 | 12.2 % | 976 | 77.7 % |
| European Plaice | 1,870 | 6.7 % | 19,838 | 8.6 % |
| Common Shrimp | 1,578 | 5.7 % | 3,104 | 33.7 % |
| Cod | 1,428 | 5.1 % | 9,274 | 13.3 % |
| Starry ray | 1,107 | 4 % | 0 | 100 % |
| European Flounder | 631 | 2.3 % | 2,142 | 22.7 % |
| Long-Rough Dab | 472 | 1.7 % | 256 | 64.9 % |
| Whiting | 420 | 1.5 % | 2,212 | 16 % |
| North Deepwater Prawn | 392 | 1.4 % | 2,474 | 13.7 % |
| Caridea shrimp | 380 | 1.4 % | 0 | 100 % |
| European hake | 312 | 1.1 % | 3,125 | 9.1 % |
| Other species | 1,459 | 5.3 % | 495,516 | 0.3 % |
| Total | 27,760 | 100 % | 542,390 | 4.9 % |

The Nephrops discards have been high because of a high MLS in place in Skagerrak and Kattegat. This MLS has been reduced in 2016 with the introduction of the LO, so it is expected that discard quantities will reduce significantly. Additionally, some exemptions for high survivability can be granted for this species, which will also reduce the issue of Nephrops UUC. Making a valuable product out of previously discarded Nephrops will though be challenging, since the main reasons for discarding Nephrops are small size, broken shell, moulting/soft shell and females with eggs. The below MCRS catches will particularly present a challenge, as such materials it will have to be utilised for non-human consumption. It is likely that solutions for the production of crustaceans for non-human consumption will be different from solutions for roundfish and flatfish species.

There are a handful of harbours that stand out in regard to where the potential discards associated to landings are reported, with the six main harbours representing over 70 % of the potential discards. These harbours are distributed all over Denmark, which will most likely present a challenge when developing solutions for production of products for non-human consumption, as transportation can be difficult. Denmark is on the other hand not a big country and transport within Jutland for example is relatively simple.

The Danish sector has been exploring alternatives for producing silage onboard fishing vessels, which are showing promising results (FiskerForum, 2017). The idea is to fit vessels with automated processing units for silage, where all UUC, MCRS and RRM are grounded up and turned into silage, without the fisherman having to do much work. The silage is then simply pumped onto a truck when landing. The problem has however been that the economic margin is very low.

FRANCE

Reported discards of the French fleet fishing in the English Channel have fluctuated considerably over the past decade, from being almost non-existent in 2005 to almost 20 thousand tonnes in 2012. There are a few species that stand out with respect to reported discards, with whiting, common dab, Atlantic herring, European Plaice and scallop representing 80 % of the discards 2010-2013 as shown in Figure 21 (STECF, 2014).

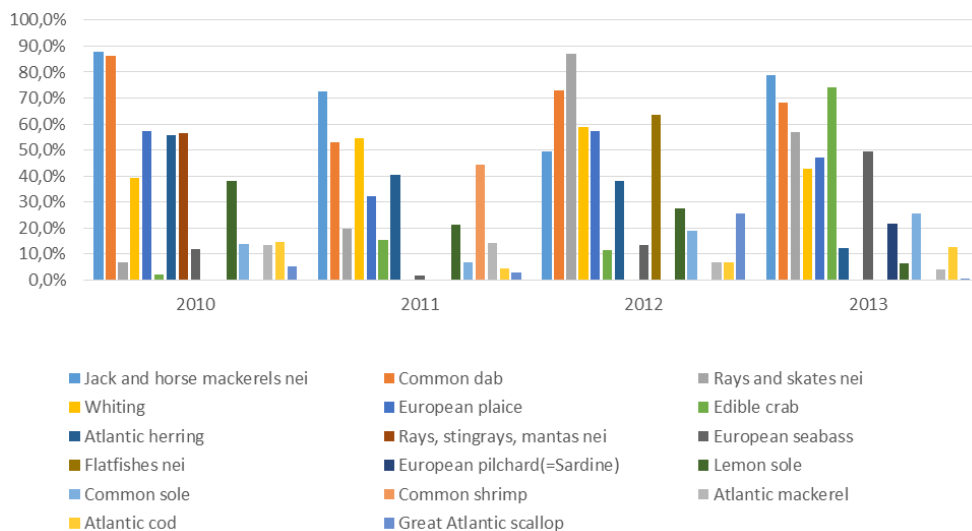
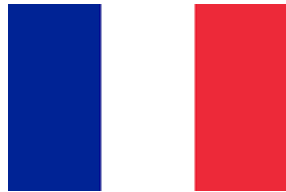

Figure 1.21: Discard ratio of France vessels in the English Channel by species (STECF, 2014).

Boulogne-Sur-Mer stands out when looking at where landings associated with discards are reported, representing around 50 % of the total discard amounts that could potentially be landed there. The rest of the 170 harbours are far behind when looking at potential discard volumes, where the harbour with the second highest potential discard volumes represents 7 % of the discards. There are some seasonal variations in the discards, as the volumes have been highest in the first and last quarter of the year. These variations depend largely on the seasonal nature of what species are being targeted, which subsequently has considerable effects on reported discards in some of the harbours i.e. fleets in some of the French harbours are mainly targeting specific species. The datasets analysed do not give information on whether discards have been obligatory MLS discards or not, which makes it difficult to estimate what parts of the UUC that will be landed once the LO is implemented will need to be used for production of products intended for non-human consumption. It is however

evident that investment in large scale facilities for processing catches below MCRS for non-human consumption will be concentrated on relatively few harbours, simply because most harbours lack critical mass. Catches below MCRS will most likely have to be transported between harbours and it might even be economically practical to concentrate all of the efforts on the vicinity of Boulogne-Sur-Mer, given that potential discard volumes there exceed the second largest discard harbour sevenfold. The company Copalis is located in Boulogne-Sur-Mer and is currently producing a variety of products from UCC and RRM. They will most certainly be a key player in utilising the UUC that prior to the LO have been discarded.

SPAIN – BASQUE COUNTRY

Reported annual landings of the Spanish fleet landing in the Basque country have been around 80 thousand tonnes for the past decade. Significant parts of these catches are coming from the Bay of Biscay. The landing and discard volumes are extremely variable between years, seasons and fleet types, which makes it difficult to predict future landings of UUC when LO comes into effect. The species that represent majority of discards are Horse mackerel, mackerel, blue whiting, hake and whiting. The available data does not give any indications of what the incentives for discarding are, but MLS is the most logical explanation. Harbours with significant landing volumes in the Basque county are few and fairly close to one another. Common facilities for utilising below MCRS catches could therefore be an applicable solution. Table 1.s2 show discard rates of the Spanish trawl fleet 2011-2013 (SDSP, 2015).



Table 1.2: Discard ratios of the Spanish pair bottom trawl fleet (PTB) and bottom otter trawlers (OTB) targeting demersal species fleet (OTD) in the Bay of Biscay 2011-2013

| Species – (PTB) | 2011 | 2012 | 2013 | Species – (OTB) | 2011 | 2012 | 2013 |
|----------------------|------|------|------|----------------------|------|------|------|
| Anglerfish | 0 % | 0 % | 0 % | Anglerfish | 3 % | 0 % | 2 % |
| Black-bellied angler | 1 % | 0 % | 0 % | Black-bellied angler | 5 % | 2 % | 3 % |
| Blue whiting | 8 % | 88 % | 39 % | Blue whiting | 98 % | 95 % | 99 % |
| Hake | 1 % | 5 % | 6 % | Hake | 65 % | 27 % | 39 % |
| Horse mackerel | 53 % | 82 % | 85 % | Horse mackerel | 94 % | 84 % | 87 % |
| Mackerel | 55 % | 51 % | 15 % | Mackerel | 99 % | 80 % | 99 % |
| Whiting | 0 % | 0 % | 0 % | Megrim | 4 % | 1 % | 3 % |

It is likely that catches of MCRS pelagics will account for the mainstay of UUC under the LO and the available infrastructure for processing such materials are primarily for fishmeal and fish oil. The company Barna AS is for example well equipped to deal with these materials coming from the Spanish fleet fishing in the Bay of Biscay.



INTERVIEWS WITH STAKEHOLDERS

The attitude of stakeholders to discard bans may depend to a large extent on the countries they live in and the sector they are operating within. Fishermen in countries such as Iceland and Norway have had approximately 40 years to get used to the concept and at this point they may be more accepting of a discard ban than fishermen in the EU who are trying to work out what impact the LO will have on their operations (Fitzpatrick and Nielsen, 2016). Fishermen in Iceland and Norway have learned that there is a value in the by-catches and that by discarding they are basically throwing away part of their wages (Viðarsson et al, 2015). EU vessels on the other hand are mainly not yet equipped to deal with these material streams nor is the market ready at present to pay high prices for these materials.

It needs also to be taken into consideration that the EU fleet is largely made up by small vessels, as 85% of the fleet is below 12 meters and 97% below 24 meters (EU, 2016). This severely reduces the alternatives available to fishermen for collecting and storing UUC onboard.

The comparison between the North and the South is also another factor that makes comparison difficult. Fishermen in the Mediterranean, Bay of Biscay and Celtic Seas may be catching up to 60-80 different species in a single fishing trip, whilst Icelandic and Norwegian fishermen usually only have to deal with 10-20 different species. This species diversity can create additional difficulties in collecting and storing UUC.

Processors in all of the countries discussed in this report are positive when asked about opportunities they see in UUC and RRM. The opportunities for new products are seemingly endless and some processors have even boldly claimed that in the near future the value of by-products will exceed the value of the fillets (Pálsson, 2013). The problem processors are however faced with at present is that they do not know how much volume will be available to justify investing in new processing facilities and technology. Initial indications are that where implementation of the LO has already begun the landings volumes of UUC are extremely small (European Commission, 2017; European Commission, 2018). Based on reported discards prior to the implementation of the LO, it would have been expected that landings of MCRS catches around the Baltic, in Denmark, France and UK would be thousands of tonnes by now; but that is not the case. For this reason it is difficult for processors to invest in expensive technology to process materials that have not yet been landed in significant quantities.



ONBOARD HANDLING OF UUC

The simplest way of dealing with UUC onboard and under the LO is to use the current setup. Species not subjected to catch limits can continue to be discarded and species for which the vessel does not have quota will have to be handled as target catch. The only catches needing to be handled differently under the LO is therefore catches under MCRS. Since MCRS catches cannot be utilised for human consumption there will be a need to separate between the two categories. It is relatively simple and inexpensive to separate between human and non-human consumption catches on the processing deck and in the hold, as long as the necessary space is available. A by-catch collection can be used to store the UUC while the target catches are being processed; and the UUC then be handled afterwards. A part of the hold can be boxed off for storing catches intended for non-human consumption and having differently coloured tubs/boxes for those catches will also be beneficial. The MCRS catches should ideally be sorted by species into the tubs/boxes, but it could also be an option to do the sorting during landing. Storing the UUC in the hold will of course have effect on how much target catch can be fit in the hold and potentially result in shortening of fishing trips, as the hold will fill up quicker. This should however not be a major problem as the vessels rarely come to port fully loaded prior to the implementation of the LO. In some instances, the space occupied by MCRS catches in the hold will result in shortening of fishing trips, which may lead to increased oil consumption, as extra fishing trips will be needed to fill the quota. This alternative is therefore simple, inexpensive to implement and applicable in most respect. But does require significant efforts from the crew and gives little economic incentive.

On large vessels and trawlers, there is an option to install an automated size grader and in some instances, it is even theoretically possible to have an automated species grader; but such a solution is not commercially available yet where there are a large number of species being caught and current legislation may not permit their use (EU Regulation 850/98, EC, 1998). There is though already marketed computer vision technology being used for species identification, but that can at present only separate between limited number of species (3X/Skaginn). Using computer vision and automatic size grading are however solutions that are not permitted onboard EU vessels, as they can enable automated high-grading. Automated size graders are on the other hand being used onboard Norwegian, Icelandic and Faroese fishing vessels; and the experience they have is that the graders have not been used to assist with high-grading (at least as far as the authors are aware). These are therefore solutions that should be considered as alternatives.

In cases where all catches being sent through the processing line are of the same species, which is quite common when fishing in the NE-Atlantic, it is possible to have an automated grading system onboard the vessel. These grading systems are for example being used on some Icelandic wetfish trawlers and amongst the equipment providers are Marel and 3X-Technology. Each batch is then ready to be sent down to the hold when the pre-decided batch size has been reached. Each tub will then contain the right amount of fish, which will all be of similar size. It is even possible to let the



data follow the tub, given that the tubs are fitted with a microchip (RFID) and the crew down in the hold have handheld scanners to connect the chip to the data collected by the grader. During on-land processing the production managers will then have detailed information on the raw material they have and can scan each tub to see what is in it, as well as where and when it was caught etc. This is a system that has for example been partly in operation at FISK Seafoods and Gunnvör in Iceland; and HB Grandi is adopting this system on the new wetfish trawlers they recently got. This kind of size grading system would be very helpful in separating between MCRS catches and catches intended for human consumption; in addition to allowing for better production management after landing.

The economic benefits of investing in size- or species graders are not that clear, as the manual grading does not really cost anything for the vessel owners. It is a task that is simply a part of what the crew does onboard the vessel. Improved grading, more uniformed batches and increased data availability are however factors that could potentially be of economic benefit for the vessel owners. The French EODE project (Balazuc et al, 2016) found that significant investment could be required to conduct shore based grading of unwanted catches.



SAFETY AND QUALITY CRITERIA FOR UUC

Different regulations may apply in regard to food safety, traceability or quality criteria depending on the intended use of UUC, for example whether it is to be used for human consumption, feed production, extraction of biomolecules or for other uses. Following is a brief discussion on regulations, safety and quality criteria's that need to be considered in regard to UUC.

HUMAN CONSUMPTION

Food safety is one of the issues that need to be a top priority when considering utilisation of UUC and RRM. The safety of these materials is closely related to the quality and need to meet traceability standards. In 2002, the European Parliament and the Council adopted Regulation (EC) No 178/2002 laying down the general principles and requirements of food law (General Food Law Regulation) establishing the European Food Safety Authority and laying down procedures in matters of food safety' and the 'Hygiene Package', a term that refers to a group of Regulations that came into force on 1st of January 2006: Regulation (EC). 852/04, 853/04, 854/04 and 882/04.

Regulations that are also important in this respect are 'Regulation (EC) 2073/05 on microbiological criteria for foodstuffs', Regulation (EC) 2074/05 and 2076/05, with implementing measures and Transitional arrangements of Hygiene Package respectively.

The onboard handling, the landing and later operations must meet the same standards for UUC as for other catches and products intended for human consumption. Table 1.3 gives an overview of the main regulations for safety, traceability and quality of food.

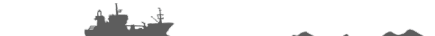

Table 1.3: Main regulations for safety, traceability and quality of food

| Regulation | Subject |
|---------------------------|---|
| Regulation (EC) 178/2002 | General principles and requirements of food law, establishing the European Food Safety Authority and laying down procedures in matters of food safety |
| Regulation (EC) 852/2004 | This Regulation lays down general rules for food business operators on the hygiene of foodstuffs |
| Regulation (EC) 853/2004 | Specific hygiene rules for food of animal origin in order to guarantee a high level of food safety and public health |
| Regulation (EC) 854/2004 | Specific rules for the organisation of official controls on products of animal origin intended for human consumption |
| Regulation (EC) 882/2004 | Official controls performed to ensure the verification of compliance with feed and food law, animal health and animal welfare rules |
| Regulation (EC) 2073/2005 | Regulation on microbiological criteria for foodstuffs |
| Regulation (EC) 1333/2008 | Food additives |
| Regulation (EU) 1169/2011 | Provision of food information to consumers |
| Regulation (EC) 258/1997 | Novel Foods and novel food ingredients |
| Directive 2004/41/EC | Repealing certain Directives concerning food hygiene and health conditions for the production and placing on the market of certain products of animal origin intended for human consumption |
| Directive 2009/32/EC | Extraction solvents used in the production of foodstuffs and food ingredients |
| Directive 2002/99/EC | Laying down the animal health rules governing the production, processing, distribution and introduction of products of animal origin for human consumption, |

ANIMAL FEED

Livestock production plays a very important part in the agricultural sector of the EU. Satisfactory results of this activity depend to a large extent on the use of safe and good quality feed. The Regulation (EC) No. 1831/2003 lays down general rules governing feed hygiene, conditions and arrangements ensuring traceability of feed as well as conditions and arrangements for registration and approval of establishments. As regarding the scope, the regulation shall apply to: (a) the activities of feed business operators at all stages, from and including primary production of feed, up to and including, the placing of feed on the market; (b) the feeding of food producing animals; (c) imports and exports of feed from and to third countries.

In particular it introduces the following main elements:

- The compulsory registration of all feed business operators by the competent authority.
- Approval of feed business establishments carrying out operations involving the more sensitive substances, such as certain feed additives, pre-mixtures and compound feeding stuffs.
- The approval system for feed businesses for the cases dealing with more sensitive substances will be maintained but provisions are made to extend the current scope for the approval requirement when necessary.
- To ensure that all feed businesses operate in accordance with harmonised hygiene requirements.
- To implement the application of good hygiene practice at all levels of agriculture production and use of feed.
- To introduce the Hazard Analysis Critical Control Point (HACCP) principles for the feed business operators other than at the level of primary production.
- Community and national guides to good practice in feed production.
- To introduce compulsory requirements for feed production at farm level.
- To provide for a European Union framework for guides to good practice in feed production.

Table 1.4 gives an overview of the main regulations relevant for safety, traceability and quality of feed within the EU.



Table 1.4: Main regulations for safety, traceability and quality of feed

| Regulation | Subject |
|----------------------------|---|
| Regulation (EC) 1831/2003. | Additives for use in animal nutrition |
| Regulation (EC) 882/2004 | Official controls performed to ensure the verification of compliance with feed and food law, animal health and animal welfare rules |
| Regulation (EC) 183/2005 | Requirements for feed hygiene |
| Regulation (EC) 767/2009 | The placing on the market and use of feed |
| Regulation (EC) 1069/2009 | Health rules for animal by-products and derived products not intended for human consumption |
| Regulation (EC) 142/2011 | implementing Regulation (EC) No 1069/2009 |
| Regulation (EU) 68/2013 | Catalogue of feed materials |

These requirements for animal feeding are laid down in various Community regulations, but the most important is Regulation 1069/2009 laying down health rules for animal by-products and derived products not intended for human consumption. In this regulation, animal by-products are categorised into three specific categories which reflect the level of risk to public and animal health: Category 1, Category 2 and Category 3, demonstrated in Figure 22 (Viðarsson, Inarra, Villarreal, & Larsen, 2016).

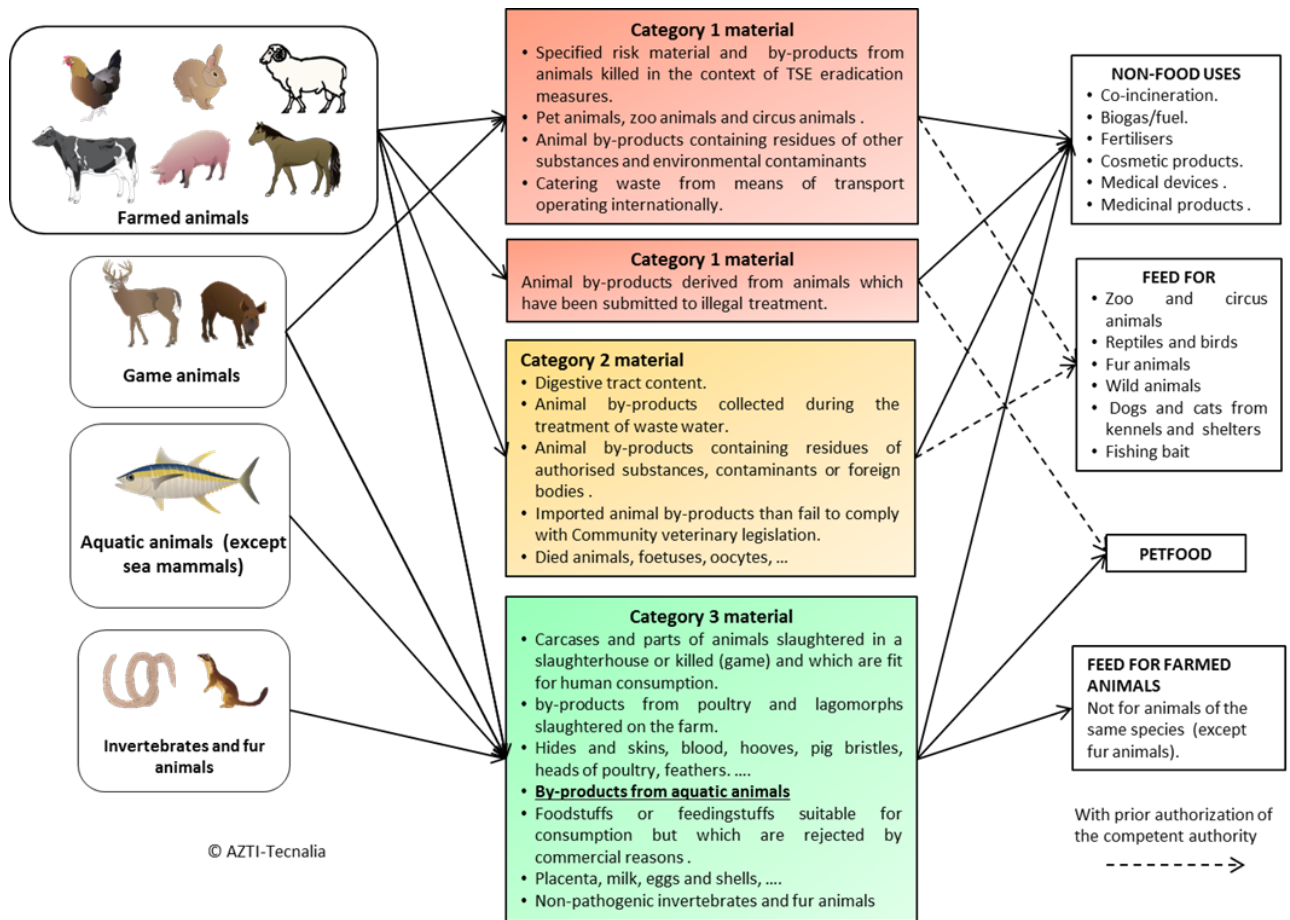

Figure 1.22: Schema of relation between by-product categories and uses

The Regulation also addresses matters such as:

- Restrictions on use.
- Disposal and use of the different categories of by-products.
- Implementing measures.
- Collection, transport and traceability.
- Registration and approval of establishments or plants.
- General hygiene requirements for establish or plants.
- Handling of animal by-products within food businesses.
- Hazard analysis and critical control points.
- Placing on the market.
- Import, transit and export
- Official controls



OTHER USES

The MCRS catches can be used for different uses than feed and food, as long as it is not used for production of products intended for direct human consumption. These can for example include extraction of biomolecules (for cosmetic or pharmaceutical uses for example) or the generation of bio-energy (bio-gas or bio-fuels as example). For these uses, quality criteria may be more important than safety or traceability.

For the obtaining of high value biomolecules, the onboard handling, landing, transport and other steps in the value chain; from capture to transformation should focus on maintaining the quality and quantity of the specific biomolecule. In most cases the handling and traceability requires similar limitations as for materials intended for direct human consumption.

Bio-energy production has few limitations, as it may use any kind of UUC and condition is generally not a major factor. The value generation potentials can however be affected by biomass degradation and documentation is generally required to validate what raw materials are used for the production.

SUMMARY OF SAFETY AND QUALITY CRITERIA'S RELEVANT FOR UUC

Summing-up the most important regulations relevant for safety and quality of UUC and potential products produced from such materials in the EU, the general rule is that all landings intended for human consumption are subjected to the same requirements. It does not make any difference whether the raw materials are from target catches or UUC.

UUC that are not intended for direct human consumption require different treatment and are to be kept separate from catches intended for human consumption. This basically means that treatment, processing and storage needs to be separated early on in the supply chain, possibly immediately after capture and at least before processing. It is important to prevent any chances of cross-contamination, which depends on certain characteristics of the UUC and treatment. In most cases it is necessary no later than in landing ports to define into what production flow the catch is going.

Taking into account that catches will degrade if the storage conditions are not appropriate, they must be stored in accordance with requirements of the final product in mind. Each production alternative requires specific structures for each stage of the supply chain i.e. for stage, crushing; drying or packing etc. Regulation EC 142/2011 is particularly important in this respect, laying down that unprocessed Category 3 materials destined for the production of feed or pet food must be stored and transported chilled, frozen or ensiled, unless it is processed within 24 hours after collection or after the end of storage in chilled or frozen form.



Safety criteria's relevant for UUC utilisation are fairly straight forward and need to apply to established rules and regulations. There is a fundamental difference in requirements for UUC intended for direct human consumption and catches that are used for other purposes, but traceability and documentation verifying that the products are safe are always required. When it comes to quality criteria's requirements can be more subjective, as long as the products are safe.



SECTION 2: IDENTIFYING BEST USES FOR UNWANTED CATCHES IN AN IRISH CONTEXT

This section of the report focuses on identifying best uses UUC in an Irish context, based on the analysis in section 1 of the report. This is based on factors such as: likely volumes, existing/available infrastructure and route to market. Potential barriers (e.g. economic, legislative, volume, handling, infrastructural deficiencies, cost of logistics) that can inhibit uses of UUC in Ireland are also identified and analysed.

The first part of this section is an analysis of landings and discard data for species subject to the LO and the projection of likely unwanted catch figures from these datasets. Due to the uncertainty associated with such a projection co-operation with relevant Marine Institute and BIM staff was essential at this stage.

The second part of this section reports on meetings and interviews with sales agents, industry reps and relevant processing companies in order to get their views on likely volumes, constraining factors, infrastructural requirements, market and other economic issues. This stage also involved the collection of cost and revenue data which informed the cost effectiveness assessments which is presented in Section 3.

BREAKDOWN OF IRISH LANDINGS AND DISCARDS OF DEMERSAL TAC SPECIES

The tables and data below are based on extraction and further analysis of data from the EU Scientific, Technical and Economic Committee for Fisheries (STECF) database of European fisheries landings and discards (<https://stecf.jrc.ec.europa.eu/dd/effort/graphs-annex>). Data was also sourced from official Irish landings figures data and port based breakdown of landings as reported under the Data Collection Framework (DCF).

Table 2.1 gives an overall breakdown of landings and reported discards (averaged between 2014 to 2016) of the main demersal species by Irish vessels using all gears in Irish waters. From this table it is evident that significant overall discard quantities should be expected to be landed by the Irish fleet under the LO and that discard rates² for certain species are also significant.

² The discard rate is calculated as follows: Discard Rate = Discards/(Discards + Landings(tonnes))



Table 2.1: Average tonnes (2014-2016) demersal catches and discards in ICES Areas VI and VII by Irish vessels (all gears, all vessel lengths, demersal TAC species).

| Irish vessels, All Gears, Areas VI & VII (excl VIId) | | | |
|--|--------------|--------------|------------------|
| Annual average 2014-16 | | | |
| Species | Discards (t) | Landings (t) | Discard Rate (%) |
| Whiting | 3686 | 7189 | 34 |
| Haddock | 2898 | 3539 | 45 |
| Nephrops | 1573 | 9164 | 15 |
| Hake | 1016 | 2943 | 26 |
| Monk | 820 | 4096 | 17 |
| Plaice | 612 | 448 | 58 |
| Megrim | 587 | 3092 | 16 |
| Cod | 336 | 1241 | 21 |
| Ling | 153 | 622 | 20 |
| Saithe | 33 | 939 | 3 |
| Black Sole | 26 | 194 | 12 |
| Pollock | 15 | 1096 | 1 |
| Total | 11756 | 34564 | 25 |

From Table 2.1 it is apparent that only nine TAC species have over 100 tons of reported annual discards associated with them. As this project is essentially focussed on species that are likely to generate significant volumes of discards the analysis will focus on these nine species. Given that the table above covers all Irish waters and all landing ports it is unlikely that Pollock, Sole and Saithe would generate volumes of discards significant enough at a specific time and specific port to justify a specific usage analysis.

In order to further explore where the majority of these discards are occurring Tables 2.2 and 2.3 show a similar breakdown for ICES Area VII and Area VI separately and only including the nine species with significant discard quantities overall.

Table 2.2: Average tonnes (2014-2016) demersal catches and discards in ICES Areas VII (excluding VIId) by Irish vessels (all gears, all vessel lengths).

| Irish vessels, All Gears, ICES Area VII (excl VIId) | | | |
|---|--------------|--------------|------------------|
| Annual average 2014-16 | | | |
| Species | Discards (t) | Landings (t) | Discard Rate (%) |
| Whiting | 3530 | 7094 | 33 |
| Haddock | 2649 | 2501 | 51 |
| Nephrops | 1570 | 9085 | 15 |
| Hake | 957 | 2715 | 26 |
| Monk | 775 | 3457 | 18 |
| Plaice | 576 | 422 | 58 |
| Megrim | 539 | 2518 | 18 |
| Cod | 310 | 1214 | 20 |
| Ling | 109 | 514 | 17 |
| Total | 11015 | 29521 | 27 |
| % of VI & VII total | 94 | 91 | |

Table 2.3: Average tonnes (2014-2016) demersal catches and discards in ICES Areas VI by Irish vessels (all gears, all vessel lengths).

| Irish vessels, All Gears, Area VI | | | |
|-----------------------------------|--------------|--------------|------------------|
| Annual average 2014-16 | | | |
| Species | Discards (t) | Landings (t) | Discard Rate (%) |
| Haddock | 248 | 1038 | 19 |
| Whiting | 156 | 95 | 62 |
| Hake | 59 | 228 | 21 |
| Megrim | 48 | 574 | 8 |
| Ling | 45 | 108 | 29 |
| Monk | 45 | 639 | 7 |
| Plaice | 37 | 26 | 58 |
| Cod | 26 | 27 | 49 |
| Nephrops | 3 | 78 | 3 |
| Total | 667 | 2813 | 19 |
| % of VI & VII total | 6 | 9 | |

As ICES Area VI accounts for less than 6% of the total demersal discarding of the nine key species, the focus of this analysis will be on the discarding activity among different gear types and fleets in Area VII.

Table 2.4: Average tonnes (2014-2016) demersal catches and discards in ICES Areas VII by Irish otter trawl vessels (all vessel lengths).

| Otter trawls, Area VII (excl VIId) | | | |
|------------------------------------|--------------|--------------|------------------|
| Annual average 2014-16 | | | |
| Species | Discards (t) | Landings (t) | Discard Rate (%) |
| Whiting | 3418 | 6557 | 34 |
| Haddock | 2277 | 2122 | 52 |
| Nephrops | 1570 | 8913 | 15 |
| Hake | 784 | 1770 | 31 |
| Megrim | 463 | 1823 | 20 |
| Monk | 359 | 2761 | 12 |
| Plaice | 286 | 276 | 51 |
| Cod | 222 | 928 | 19 |
| Ling | 57 | 343 | 14 |
| Total | 9437 | 25493 | 27 |
| % of Area VII total | 86 | 86 | |

Table 2.5: Average tonnes (2014-2016) demersal catches and discards in ICES Areas VII by Irish beam trawl vessels (all vessel lengths).

| Beam trawls, Area VII (excl VIId) | | | |
|-----------------------------------|-------------|-------------|--------------|
| Annual average 2014-16 | | | |
| Species | Discards | Landings | Discard Rate |
| Haddock | 369 | 213 | 63 |
| Monk | 307 | 584 | 34 |
| Plaice | 234 | 138 | 63 |
| Hake | 105 | 91 | 53 |
| Whiting | 85 | 33 | 72 |
| Cod | 70 | 150 | 32 |
| Megrim | 70 | 665 | 9 |
| Ling | 48 | 75 | 39 |
| Nephrops | 0 | 15 | 0 |
| Total | 1288 | 1964 | 40 |
| % of Area VII total | 12 | 7 | |

Tables 2.4 and 2.5 illustrate that only two gear types, bottom trawls in particular and beam trawls to a lesser extent, account for 98% of Area VII discards of the nine key species.

A comparison of Table 2.4 and Table 2.5 shows that the majority of discards for the nine species in Area VII are generated by the otter trawl fleet. Discard rates however for beam trawlers are higher on average, at 40% across the nine species, than those for otter trawlers at 27%. Despite the fact that there are some very high discard rates listed in these tables (e.g. 72% for Whiting caught by beamers in Area VII) the emphasis of this report is not on reducing discard rates, but on analysing where the greatest volumes of discards originate from, where they are likely to be landed and the utilisation options for those volumes.

The STECF database allows for further analysis of the bottom trawl fleet by looking at mesh size and vessel length subdivisions and Tables 2.6 to 2.9 indicate the proportion of landings and discards accounted for by under and over 15m vessels using trawls and seines with either 70-99mm (TR2) mesh size or 100mm (TR1) mesh size and over.

Table 2.6: Average tonnes (2014-2016) catches and discards in ICES Areas VII by Irish 10-15 metre TR1 vessels (using bottom trawl or seine equal to or greater than 100 mm mesh size).

| TR1 10-15m, Area VII (excl VIId) | | | |
|----------------------------------|--------------|--------------|------------------|
| Annual average 2014-16 | | | |
| Species | Discards (t) | Landings (t) | Discard Rate (%) |
| Whiting | 57 | 90 | 39 |
| Haddock | 45 | 38 | 54 |
| Monk | 16 | 42 | 28 |
| Nephrops | 14 | 79 | 15 |
| Hake | 10 | 14 | 41 |
| Megrim | 10 | 47 | 17 |
| Plaice | 5 | 5 | 49 |
| Cod | 5 | 12 | 28 |
| Ling | 1 | 5 | 16 |
| Total | 163 | 333 | 33 |
| % of Area VII total | 2 | 1 | |

Table 2.7: Average tonnes (2014-2016) demersal catches and discards in ICES Areas VII by Irish TR1 vessels (bottom trawl or seine equal to or greater than 100 mm mesh size) over 15 metres.

| TR1 Over 15m, Area VII (excl VIId) | | | |
|------------------------------------|--------------|--------------|------------------|
| Annual average 2014-16 | | | |
| Species | Discards (t) | Landings (t) | Discard Rate (%) |
| Whiting | 1829 | 4176 | 30 |
| Haddock | 1238 | 1521 | 45 |
| Hake | 369 | 1473 | 20 |
| Nephrops | 288 | 2288 | 11 |
| Megrim | 187 | 1245 | 13 |
| Monk | 169 | 1687 | 9 |
| Cod | 146 | 659 | 18 |
| Plaice | 96 | 214 | 31 |
| Ling | 25 | 245 | 9 |
| Total | 4348 | 13507 | 24 |
| % of Area VII total | 42 | 46 | |

Table 2.8: Average tonnes (2014-2016) demersal catches and discards in ICES Areas VII by Irish 10-15m TR2 vessels (bottom trawl or seine 70-100 mm mesh size).

| TR2 10-15m, Area VII (excl VIId) | | | |
|----------------------------------|--------------|--------------|------------------|
| Annual average 2014-16 | | | |
| Species | Discards (t) | Landings (t) | Discard Rate (%) |
| Whiting | 200 | 110 | 64 |
| Haddock | 170 | 80 | 68 |
| Nephrops | 133 | 575 | 19 |
| Hake | 44 | 13 | 77 |
| Monk | 39 | 152 | 20 |
| Megrim | 39 | 106 | 27 |
| Plaice | 22 | 22 | 51 |
| Cod | 12 | 17 | 42 |
| Ling | 4 | 4 | 50 |
| Total | 663 | 1078 | 38 |
| % of Area VII total | 6 | 4 | |

Table 2.9: Average tonnes (2014-2016) demersal catches and discards in ICES Areas VII by Irish over 15m TR2 vessels (bottom trawl or seine 70-100 mm mesh size).

| TR2 Over 15m, Area VII (excl VIId) | | | |
|------------------------------------|--------------|--------------|------------------|
| Annual average 2014-16 | | | |
| Species | Discards (t) | Landings (t) | Discard Rate (%) |
| Nephrops | 1106 | 5968 | 16 |
| Whiting | 1036 | 2180 | 32 |
| Haddock | 771 | 482 | 62 |
| Hake | 339 | 269 | 56 |
| Megrim | 239 | 425 | 36 |
| Monk | 139 | 873 | 14 |
| Plaice | 65 | 34 | 65 |
| Cod | 55 | 240 | 19 |
| Ling | 26 | 89 | 23 |
| Total | 3776 | 10561 | 26 |
| % of Area VII total | 36 | 36 | |

It is probably safe to assume that any previously discarded catch which is above the Minimum Conservation Reference Size (MCRS) will be disposed of on the human consumption market. The main interest in this study is therefore in utilisation of those previously discarded fish, which are smaller than the MCRS. Article 15 of the 2013 Common Fisheries Policy states that “the use of catches of species below the minimum conservation reference size shall be restricted to purposes other than direct human consumption, including fish meal, fish oil, pet food, food additives, pharmaceuticals and cosmetics” (EU, 2013). Estimates of the proportion of discards below MCRS in Table 2.10 have been sourced from Hedley and Catchpole, 2015. For Nephrops the figure for the proportion of discards below MCRS was calculated by using the figure of 7% of total Nephrops catch below MCRS from a report by BIM on catch composition in Celtic Sea Nephrops trawls (BIM, 2015) and applying it to the total Irish Nephrops catch. It must be stressed however that due to the numerous uncertainties which could affect implementation of the LO as well as uncertainties within the estimation process, the figures below should be treated only as indicators of potential volumes of below MCRS fish which may be landed.

Table 2.10: Estimated potential volume (tonnes) of unwanted catch (below MCRS) for eight key demersal species (Monkfish is not included here as there is no MCRS specified for monkfish).

| Irish vessels, All Gears, Areas VI & VII (excl VIId) | | | |
|--|-------------------|------------------|-------------------------|
| Annual average 2014-16 | | | |
| Species | Discards (tonnes) | % discards <MCRS | Discards <MCRS (tonnes) |
| Whiting | 3686 | 39 | 1438 |
| Haddock | 2898 | 49 | 1420 |
| Nephrops | 1573 | 48 | 752 |
| Hake | 1016 | 46 | 467 |
| Plaice | 612 | 44 | 269 |
| Cod | 336 | 67 | 225 |
| Ling | 153 | 46 | 71 |
| Megrim | 587 | 6 | 35 |
| Total | 11756 | 40 | 4678 |

The total figure for below MCRS discards of these eight species in Area VII by all Irish vessels is projected to be 4,678 tonnes based on the method outlined above. This is a highly significant amount and as a comparison the figure is larger than the annual landings total for all except for the top six Irish ports. Only six species are likely to have below MCRS quantities of over 200 tons per year and we will therefore further focus our analysis on these. Of the top six species four are gadoids, one is a flatfish and one is a shellfish species.

Table 2.11 shows that projected below MCRS quantities equate to 19% of the total annual average landings for these species between 2014 and 2016. Furthermore the ratio of below MCRS fish to annual landings for certain species could be much higher and up to 60% for Plaice. It is clear from the projections in Tables 2.10 and 2.11 that if comparable quantities of small fish are going to be landed in the future this would create a significant utilisation challenge. This is dealt with in greater detail in Section 3.

Table 2.11: Ratio of <MCRS unwanted catch to average annual landings.

| Irish vessels, All Gears, Areas VI & VII (excl VIId) | | | |
|--|-------------------------|-------------------|------------------------|
| Annual average 2014-16 | | | |
| Species | Discards <MCRS (tonnes) | Landings (tonnes) | <MCRS as % of landings |
| Whiting | 1438 | 7189 | 20 |
| Haddock | 1420 | 3539 | 40 |
| Nephrops | 752 | 9164 | 8 |
| Hake | 467 | 2943 | 16 |
| Plaice | 269 | 448 | 60 |
| Cod | 225 | 1241 | 18 |
| Total | 4572 | 24524 | 19 |

In order to assess where these below MCRS fish are most likely to be landed we have used the landings figures for the main ports broken down by each of the six species we are focussing on. Table 2.12 shows the overall landings volume and value in the main ports in 2015 and 2016 (BIM Business of Seafood, 2016). Table 2.13 shows the estimated volume of below MCRS discards which would be landed based on the assumption that the distribution of below MCRS discards by port is the same as that for commercial landings for each of the six species.

Table 2.12: Volumes and values of landings at the top 10 Irish ports in 2015 and 2016.

| Port | Volume (tons) | | | Value € million | | | Notes |
|----------------|---------------|--------|---------|-----------------|------|---------|--|
| | 2016 | 2015 | Average | 2016 | 2015 | Average | |
| Killybegs | 155500 | 148746 | 152123 | 85 | 81 | 83 | 78% pelagic, 20% demersal, 20% foreign |
| Castletownbere | 39700 | 45763 | 42732 | 111 | 113 | 112 | 70% foreign |
| Dingle | 10500 | 12611 | 11556 | 23 | 29 | 26 | 76% foreign |
| Dunmore East | 10400 | 10978 | 10689 | 19 | 16 | 18 | 46% Demersal |
| Howth | 6000 | 4411 | 5206 | 16 | 12 | 14 | 15% demersal, 79% shellfish |
| Kilmore Quay | 5500 | 4437 | 4969 | 13 | 16 | 15 | 51% demersal, 48% shellfish |
| Ros a Mhil | 3300 | 3637 | 3469 | 14 | 12 | 13 | 12% demersal, 78% shellfish |
| Greencastle | 3600 | 2826 | 3213 | 9 | 7 | 8 | 81% demersal, 10% foreign |
| Union Hall | 2400 | 2286 | 2343 | 9 | 7 | 8 | 43% demersal, 56% shellfish |
| Clogherhead | 1900 | 1555 | 1728 | 9 | 6 | 8 | 91% shellfish |

Source: BIM Business of Seafood reports 2015 and 2016. (Note: includes landings by foreign vessels).

Table 2.13: Estimated potential volumes (tonnes) of unwanted catches (below MCRS) of 6 key species in the main Irish ports.

| Port | Whiting | Haddock | Hake | Cod | Plaice | Nephrops | Total | Total Gadoids |
|----------------|-------------|-------------|------------|------------|------------|------------|-------------|---------------|
| Dunmore East | 661 | 295 | 34 | 56 | 20 | 135 | 1201 | 1046 |
| Castletownbere | 332 | 361 | 208 | 46 | 19 | 114 | 1080 | 947 |
| Greencastle | 174 | 343 | 49 | 16 | 14 | 6 | 602 | 582 |
| Kilmore Quay | 110 | 118 | 51 | 40 | 17 | 28 | 364 | 319 |
| Union Hall | 34 | 93 | 33 | 30 | 8 | 70 | 268 | 190 |
| Killybegs | 36 | 94 | 14 | 4 | 6 | 5 | 159 | 148 |
| Howth | 30 | 46 | 2 | 21 | 94 | 173 | 366 | 99 |
| Dingle | 15 | 16 | 60 | 3 | 0 | 23 | 117 | 94 |
| Clogherhead | 34 | 32 | 5 | 8 | 88 | 72 | 239 | 79 |
| Ros A Mhil | 14 | 22 | 10 | 2 | 3 | 126 | 177 | 48 |
| Total | 1440 | 1420 | 466 | 226 | 269 | 752 | 4573 | 3552 |

Source: Official Irish landings figures data and port based breakdown of landings as reported under the Data Collection Framework (DCF).

Table 2.14: Estimated total unwanted catch volumes (tonnes) for 6 key species in the main Irish ports, landings by Irish vessels in those ports, unwanted catches as a percentage of total key species landings.

| Port | <MCRS key species (tonnes) | Total Irish landings | Irish landings key species | <MCRS as % of key sp. landings |
|----------------|----------------------------|----------------------|----------------------------|--------------------------------|
| Dunmore East | 1201 | 10189 | 5066 | 24 |
| Castletownbere | 1080 | 14008 | 4583 | 24 |
| Greencastle | 602 | 3298 | 1819 | 33 |
| Kilmore Quay | 364 | 5466 | 1409 | 26 |
| Union Hall | 268 | 2305 | 1378 | 19 |
| Killybegs | 159 | 152123 | 490 | 32 |
| Howth | 366 | 5703 | 2303 | 16 |
| Dingle | 117 | 11556 | 668 | 18 |
| Clogherhead | 239 | 1834 | 1164 | 21 |
| Ros A Mhil | 177 | 3074 | 1525 | 12 |
| Total | 4573 | 209556 | 20405 | 22 |

Both Table 2.13 and 2.14 show that projected below MCRS quantities will be significant and furthermore that they represent a significant proportion of landings of the six key species when examined on a port basis. The significance and likely consequences of this are discussed in greater detail later in Section 3 of the report.

BREAKDOWN OF IRISH LANDINGS AND DISCARDS OF PELAGIC TAC SPECIES

Discard rates in pelagic fisheries are generally much lower than in demersal fisheries, but the quantities can however be substantial. Discards in both the Irish mackerel and blue whiting fisheries were above 3,000 tonnes in 2016, as shown in the tables 2.15 to 2.19 below (Data for this section was taken from an exercise examining pelagic and demersal discards conducted by the Pelagic Advisory Council using a Choke Mitigation Tool which was based on the STECF landings and discards database <https://stecf.jrc.ec.europa.eu/dd/effort/graphs-annex>).

Table 2.15: Mackerel landings and discards 2016 (tonnes) by Irish vessels in all areas.

| | |
|-------------------------------|-------------|
| Reported landings 2016 (t) | 77520 |
| Reported discards 2016 (t) | 3247 |
| Discard rates 2016 (%) | 4% |
| Demersal landings 2016 (t) | 9 |
| Demersal Discards 2016 (t) | 115 |
| Total demersal catch 2016 (t) | 124 |
| % of Total catch | 0.2% |
| Total catch 2016 (tonnes) | 80767 |

Table 2.16: Herring landings and discards (tonnes) 2016 by Irish vessels in all areas.

| | Celtic Sea | VlaS | VlaN | N Sea |
|----------------------------|------------|-----------|----------|----------|
| Reported landings 2016 (t) | 12856 | 1172 | 569 | 127 |
| Reported discards 2016 (t) | 88 | 32 | 2 | 0 |
| Discard rates 2016 (%) | 1% | 3% | 0% | 0% |
| Demersal landings 2016 | 57 | 0.03 | 0.00 | 0 |
| Demersal Discards 2016 | 86 | 32.00 | 0.00 | 0 |
| Total demersal catch 2016 | 143 | 32.03 | 0.00 | 0 |
| % of Total catch | 1.1% | 2.7% | 0.0% | 0.0% |
| Total catch 2016 (t) | 12944 | 1204 | 571 | 127 |

Table 2.17: Blue Whiting landings and discards (tonnes) 2016 by Irish vessels in all areas.

| | |
|----------------------------|-------------|
| Reported landings 2016 (t) | 27662 |
| Reported discards 2016 (t) | 3010 |
| Discard rates 2016 (%) | 10% |
| Demersal landings 2016 | 0 |
| Demersal Discards 2016 | 275 |
| Total demersal catch 2016 | 275 |
| % of Total catch | 0.9% |
| Total catch 2016 (t) | 30672 |

Table 2.18: Horse Mackerel landings and discards (tonnes) 2016 by Irish vessels in all areas.

| | |
|----------------------------|------------|
| Reported landings 2016 (t) | 29066 |
| Reported discards 2016 (t) | 223 |
| Discard rates 2016 (%) | 1% |
| Demersal landings 2016 | 1 |
| Demersal Discards 2016 | 222 |
| Total demersal catch 2016 | 223 |
| % of Total catch | 1% |
| Total catch 2016 (t) | 29289 |



Table 2.19: Boarfish landings and discards (tonnes) 2016 by Irish vessels in all areas.

| | |
|----------------------------|-------|
| Reported landings 2016 (t) | 16325 |
| Reported discards 2016 (t) | 7 |
| Discard rates 2016 (%) | 0% |
| Demersal landings 2016 | 0 |
| Demersal Discards 2016 | 7 |
| Total demersal catch 2016 | 7 |
| % of Total catch | 0.0% |
| Total catch 2016 (t) | 16332 |



INTERVIEWS/PORT VISITS

The authors of this report had a number of meetings and interviews with sales agents, industry reps and relevant processing companies in order to get their views on likely volumes, constraining factors, infrastructural requirements, market and other economic issues. Cost and revenue data, which will inform the cost effectiveness assessments presented in the third section of this report, was also collected.

Sectors covered

- Co-op managers
- PO managers
- Pet food/Bait Company Manager
- Whitefish processors & fresh fish buyers
- Pelagic Processors
- Fishmeal and Fish Protein Plant Managers
- Enterprise Ireland Development Adviser

Ports directly covered via interviews/meetings:

- Castletownbere
- Dunmore East
- Greencastle
- Ros a Mhil
- Union Hall
- Killybegs



Interview responses:

OVERALL IMPLICATIONS OF THE LANDING OBLIGATION:

- Most found it difficult to envisage implementation of the LO due to multiple impacts on the catching sector removing any incentive to comply. In particular the impact of landing below MCRS fish on restrictive quotas such as Haddock is seen as a major implementation barrier.
- Strong support for an incremental approach based on gradual mesh size increases, discard reduction targets and spatial discard management.

GENERAL ECONOMIC ISSUES:

- There is a huge discrepancy between the value of fish for the human market and even the best-case scenario for the non-human market. Currently this is probably the bait market at a maximum price of around €400 per tonne.
- All currently available utilisation options entail significant additional costs including storage, transport and additional boxes.
- Many processors are currently not receiving any return for fish processing waste and are happy to get it off their hands. Generally they are using a mix of pet food and mink farms in such cases.
- There is the possibility of the fresh fish market price collapsing if all previously discarded fish was landed – the example given where this scenario would most likely occur was Haddock.
- Some interviewees identified the biggest problem as one of scale or volume. They felt that currently too much white fish is exported whole and until more processing happens here it may be difficult to establish alternatives to fish meal or pet food producers as utilisation options.

INFRASTRUCTURAL ISSUES

- Cold storage capacity is already limited at all co-ops. One manager said they have 1200 boxes capacity and some days they would need 3000 just for fresh fish storage. They currently get around this by using refrigerated shipping containers as a temporary measure.
- A number of fish sales organisations, such as Kingfisher Fresh, Castletownbere, Foyle and Galway and Aran Fishermen's Co-ops, have benefitted from securing funding from BIM, under the EMFF, to increase cold storage capacity which would at least partially offset projected increases in volumes of unwanted catch. However, the issue of sending partial loads of unwanted catch to the fish meal plant in Killybegs could still be an issue as fresh fish can only be kept in cold storage for a finite period before significant degradation occurs.
- If the LO were implemented now there would be a public health issue with boxes of discards being stored on piers. This would inevitably create an issue with hygiene, attract pests and provoke a negative response from the public. There is some uncertainty about whether ABP rules would allow discards to be stored with fresh fish in cold stores.

- Landing of discards would also create an infrastructural issue for skippers as they have a finite cold storage capacity on vessels which could result in trips being cut short. This is one of the findings of the French EODE project (Balazuc et al, 2016).

FISHMEAL

- See box below for estimation of additional costs for fishmeal provided by Co-Op managers.
- There is a possibility to mitigate some costs of new boxes through BIM funding and this has been successfully achieved in some cases through the securing of EMFF funding by fishermen's co-ops.
- Despite the low return for fishmeal to fishermen or co-ops after transport and other costs have been factored in there is some scepticism that any other solution will offer a better return.
- A number of interviewees expressed dissatisfaction with the fact that the only fishmeal plant had a monopoly with a negative impact on price. There is some interest in a feasibility assessment for another fishmeal plant situated somewhere in the centre or south of the country as previous viability assessments for same had included volumes of pelagic and processing waste but did not include volumes of discards. Such an inclusion may change the viability of another fishmeal plant based in the south.
- Some interviewees mentioned a proposed fish protein and oil plant based in Mitchelstown which may be taking waste and discards. Plans for this plant have now been shelved but the insight gained by the prospective operator has been very useful in compiling this report.
- There seems to be a difference in perception of the value of returns from fishmeal between pelagic processors who have traditionally used this outlet as a way to dispose of processing waste and some whole fish discarded during processing. Their view of the prices returned are more positive than demersal representatives who are looking at fishmeal revenues in comparison with the price for fresh fish and accordingly have a much more negative perception.

EXAMPLE COSTS FOR UTILISATION OF DEMERSAL FISH DISCARDS AS FISHMEAL

Co-op managers provided detailed information on costs and returns associated with converting demersal discards to fishmeal. Transport costs €40-60 per tonne depending on proximity to Ireland's only fish meal plant in Killybegs. The example given in Table 2.20 below gives a breakdown of costs based on one co-op managers figures.

An issue mentioned regarding the transport of discards to the fishmeal plant was boxes which would be temporarily missing. One co-op manager estimated that the number of boxes would need to double from the current figure of 15,000 boxes. At a cost of €11 per box that is an outlay of €165,000.

There are also costs associated with additional handling, storage and washing of boxes estimated at €40 per tonne.

These costs are not perceived as viable at a current price of approximately €120 per tonne for demersal fish at the fishmeal plant.

Further examination of this option and others is given in Section 3.

Table 2.20: Estimated summarised costs and revenue from demersal fishmeal utilisation option based on one fishermen’s co-op managers figures.

| | |
|-------------------------------------|------|
| Price per tonne Demersal fishmeal | €120 |
| Additional handling costs | €20 |
| Additional storage costs | €25 |
| Transport costs | €50 |
| Return to fisherman/Co-op per tonne | €25 |

The return for pelagic fish is higher as due to their higher oil content they receive a price of approximately €180-200 per tonne and also handling costs are slightly less due to the use of bins rather than smaller capacity fish boxes.

PET FOOD

- Pet food is perceived by some managers and processors as an occasionally higher return option than fishmeal at up to €150 per tonne. However the capacity to take significant volumes of fish is limited and suppliers felt that the pet food price would collapse in the context of landings of significant quantities of below MCRS fish.
- One pet food company manager said they received approximately 100 tonnes of discards in 2015 from vessels participating in trials but the volumes initially anticipated never materialised. There is a significant correlation between the price they can pay and the degree of mixing of species and the lowest price product they supply is a mixed fish product. DNA testing is done by his customers to ensure the species integrity of his products.
- The pet food company manager felt that there could be some added value in using discards through a Mechanically Recovered Meat process as filleting small fish, in particular where species are mixed, creates technical difficulties.
- The issue of investing in the processing of discards is complicated by the potential for the supply to shrink due to non-compliance or selectivity improvements.
- A number of co-ops and processors are disposing of their waste and discards to mink farms but they receive no economic return for this.

BAIT MARKET

- This is a “best of a bad lot” solution for some co-op managers but there may be issues with the size of the market and some supply constraints as detailed below.
- The bait market is seen by many co-op managers as an area that would have to be expanded in the context of LO implementation and landing of below MCRS unwanted catch.
- Prices for bait depend on species and pot fishery targeted.
- Prices vary from €200 per tonne for shrimp bait to a maximum of €400 per tonne which was paid by whelk fishermen for whiting discards caught in the Herring fishery in 2016.
- Whiting, Haddock and Plaice are the most common and preferred bait for many pot fishermen.
- A major constraining factor is the capacity to freeze whole fish for the bait market before the season. The bait season for most pot fisheries lasts from March to September/October.
- Setting up a bait distribution network to widely dispersed pot fishermen is also a constraint to bait supply companies.
- The size of the bait market is uncertain – one supplier stated that it could take all discards but that the price would drop if significant quantities of below MCRS discards were landed.

NEW UTILISATION OPTIONS MENTIONED BUT NOT CURRENTLY USED.

- A lot of interest was expressed in small silage units and many of those contacted would like to receive further information on the costs and viability of same. The possibility of stabilising material (i.e. stopping degradation) and allowing a full transport load to be accumulated would in itself be a step forward from the current situation whereby partial loads have to be sent to the fishmeal plant in Killybegs which further reduces the potential return to fishermen.
- The manager of the pet food company said that a significant barrier to the use of silage units in ports would be the uncertainty regarding which species have been placed in the unit. If security or certainty around this issue was guaranteed it could be a viable option.
- The biggest challenge to the use of discards in producing fish protein products (Soluble Fish Protein Hydrolysate (FPH), Partly Hydrolysed Fish Protein (PHP) and Fish Bone Powder) is the mix of species which may be the only way to generate the scale needed. Whether a mix of species can produce the consistency of end product required is still uncertain.
- Usage of prawn heads for shellfish stock. One of the Co-ops has identified an interested customer and supplied some initial quantities but quantities would likely be small.
- A very consistent message is that the higher the degree of mixing of species the lower the market price that can be achieved regardless of the utilisation method.

**OTHER COMMENTS FROM INTERVIEWEES.**

Co-op manager involved in pelagic and demersal fisheries “It’s difficult to see anything getting a better return than fishmeal.”

Co-op manager involved purely in demersal fisheries “Fish meal, possibly protein extraction or pet food may be options for us down the line. But they are still a fraction of the value of fresh fish”.

Fresh fish buyer and bait supplier “The bait market would take the entire Irish quota if it could and pot fishermen are screaming for bait this year”.

“If whitefish discards were all landed we would have a far better picture of the state of the stocks”.

Whitefish and Salmon processor who has also taken some discards “I haven’t looked into fishmeal or other disposal options, I’m just happy that I can dispose of them free of charge for pet food and mink feed”.

Pet food and bait company manager “It’s difficult to justify investing in equipment when the supply is likely to shrink every year. Already volumes that were supposed to be landed have not materialised”.

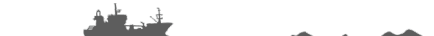

SECTION 3: COST EFFECTIVENESS ANALYSIS OF POTENTIAL USES FOR UUC

It is clear from the projections in section 2 of this report that if these quantities of small fish are going to be landed in the future a significant utilisation challenge will arise. An exploration of which utilisation options and the feasibility of these is therefore required. In this section we examine currently available and potential future utilisation options. We look at costs of infrastructure and equipment and potential revenues back to fishermen for each of these options.

The cost effectiveness analysis is based on the economic return to fishermen. Although other points further along the value chain (e.g. return to processors) are also relevant, the removal of the incentive to continue discarding is the primary goal of the LO rather than the development of further revenue streams from the processing of discards.

The cost effectiveness analysis used estimates of costs and economic returns based on some or all of the following variables: routine costs of onboard handling, cost of onboard infrastructure required, price returned to fisherman, transport costs, processors/sales organisations handling costs, infrastructure or equipment costs for processors/sales organisations, R&D costs for processors/sales organisations and sales price returned to processors/sales organisations.

Scenarios accounting for a number of future uncertainties and cost effectiveness analyses of these scenarios are also described. Additionally, the effect of factors which create uncertainty in these projections, such as future volumes of discards, are examined.

Economic data sources: The data used in this section and in the tables are based wherever possible on real data supplied by co-op managers, processors and buyers. Where additional equipment will be required we received indicative quotes from a number of suppliers. In some cases we were provided with costs for similar recently installed equipment e.g. a silage unit recently installed in the Shetlands at a cost of £140,000 Stg. Out of necessity in some cases we have averaged cost data supplied. For example, an average cost of €45 per tonne for transport to either fishmeal, pet food or protein plants in the North West of Ireland was used whereas in some cases the costs are as high as €60 per tonne even for a full load. The figures outlined in the tables in this section are averages based on data provided by a number of respondents and the figure for return to fishermen may vary for particular sales agents depending on their costs and overheads.

For the more speculative options, e.g. advanced silage processing or FPH production, firm investment cost and price information can be difficult to obtain as equipment suppliers were very keen to stress that both capital costs and operating costs are highly dependent on the specific installation context and whether synergies with existing processes could be utilised. Likewise pinning down price information for the products of some of the utilisation options is difficult due to the fact that in certain countries well developed markets and distribution networks are available which may mean

that the price available, for silage in Norway for instance, will not necessarily be achievable in Ireland. These cost and price issues are discussed in further detail below.

Although the data used in these economic projections are based as far as possible on real figures there will be situations where there will be higher costs or greater revenues than those presented in the tables. These tables are indicative only and some significant averaging to simplify presentation has been done.

Utilisation options analysed: From the inclusive list of utilisation options outlined in section 1 of this report we have identified a subset which are either currently available or which we consider to have some potential in the medium term. The chapter below (Currently available options) provides an analysis of options either currently available or which could be available with relatively small levels of investment. The section following that (Options requiring more significant investment or longer time scales) provides a further analysis of options and scenarios which may require significant investment, but which could have potentials as usage options in the Irish context.

For various reasons some utilisation options have not been analysed in this report. In some cases, this is due to the fact that certain options may not be economically viable in Ireland. An example of this is the drying of whole fish that is only feasible in Iceland and Norway due to both environmental conditions and the availability of cheap geothermal energy. Other potential uses, such as anaerobic digestion to biogas or composting have been shown in other reports (Catchpole et al, 2014) to provide no economic return to fishermen or to incur a disposal cost. As we are ideally looking for options which provide some incentive to comply with the LO rather than merely to solve a disposal problem we have not explored these options further. Another category of unwanted catch utilisation are those that will require significant investment in both infrastructure and R&D before they can be considered as economically viable options. Such options may in the future be feasible, as can be seen from the Icelandic and Norwegian experiences, where high value niche products have been developed, but our focus here is on solutions in the short or medium term.

CURRENTLY AVAILABLE OPTIONS

The authors of this report have concluded that the most applicable solutions at this time for utilising catches below MCRS in Ireland are for fishmeal, bait, pet food and silage. Table 3.1 shows the main costs and revenues associated with options currently available or in the case of silage an option which could be available with relatively small levels of investment.

The first four options in the table are already used to a significant extent as utilisation options for processing waste, pelagic fish disposal and to some extent whitefish disposal. Fishmeal is the option currently most utilised by co-ops and processors when dealing with significant volumes of fish and one reason is that the only additional costs are in transporting the fish to Killybegs. However those



transport costs are significant with a cost of €60 per tonne quoted for operators from Wexford, Cork and Kerry. Another aspect of the fishmeal option is that it delivers a relatively fixed price. Fishmeal is a global commodity and the prices are fixed according to global trends. On the positive side this means that suppliers to the fishmeal factory can be relatively certain of the price they will get but the downside is that there is a fixed ceiling to the price so the return to the fisherman for this material can only be increased by reducing costs, of which the main one is transport.

The option to sell fish as fresh bait presents the greatest return to the fisherman and one that is unlikely to be bettered in the medium term. The price per tonne for bait is based on an average of different prices reported to me by co-ops, processors and bait supply companies. In certain fisheries and at certain times higher prices may be paid for bait, for example €400 per tonne paid for Whiting discards caught in the Herring fishery in 2016. At certain times of the year significant volumes of below MCRS fish could be disposed of in this way and in some areas, there may be very low transport costs incurred also depending on whether the bait is distributed by the supplier or picked up by the buyer. However, the average return for disposal to the bait market is probably somewhere between the fresh and frozen bait columns here as for significant parts of the year when pot fishing is not occurring freezing and storage will be a necessity.

Table 3.1: Costs and revenues per tonne of utilisation options for below MCRS fish in Ireland (Costs are based on 1 tonne units (25 X 40kg boxes) of below MCRS whitefish)

| Economic variable | Fishmeal | Bait fresh | Bait frozen | Pet food | Silage basic |
|---|-----------|------------|-------------|-----------|--------------|
| Transport | 45 | 30 | 30 | 45 | 45 |
| Labour | 10 | 20 | 25 | 10 | 20 |
| Boxing | 10 | 10 | 10 | 10 | 5 |
| Cold Storage | 0 | 10 | 120 | 10 | 0 |
| Plant installation cost ¹ | 0 | 0 | 0 | 0 | 80,000 |
| Plant Capital/ton ² | 0 | 0 | 0 | 0 | 32 |
| Plant operational materials ³ | 0 | 0 | 0 | 0 | 2 |
| Energy requirement | Low | Low | Medium | Low | Low |
| Subtotal costs | 65 | 70 | 185 | 75 | 104 |
| Price per tonne from buyer | 120 | 250 | 250 | 130 | 140 |
| Net € return per tonne to fisherman | 55 | 180 | 65 | 55 | 36 |
| Currently available to Irish whitefish industry | Yes | Yes | Yes | Yes | No |

¹ Installation cost based on prices from Icelandic and Norwegian companies and a silage plant recently fitted in Shetlands by UFI.

² Based on average of 50 tons throughput per month for 10 months per annum.

³ Operating costs Acid (3.5g per 100kg @ €700 per tonne), Antioxidant (ethoxyquin) (@200ppm and €5 per kg).

Transport costs are averages based on quotes from co-op managers and processors throughout Ireland.

Cold storage costs for frozen bait are based on 2 months frozen storage @ €10 per week for 650kg pallet.

Silage price is based on indications from potential buyers for a stabilised product under controlled conditions.

We have not included additional boxing, icing and labour costs aboard the vessel as for all options, with the exception of onboard silage units, these are essentially the same.

For the pet food option, pet food companies dealing with fish products in Ireland at present currently get significant supplies of processing waste which they do not pay for but cover the cost of transport. In order for the price listed in Table 3.1, €130 per tonne, to be a realistic option the quality of the product would have to be good, species would have to be unmixed and supply quantities would have to be significant and stable.

The option to produce silage from unwanted catches is listed alongside the currently available options as it is a possibility that does not require significant investment. Additionally, it is being discussed throughout Europe as a potential option for the disposal of below MCRS catches, so it is appropriate to examine its feasibility here. The silage price listed here, €140 per tonne, is based on indications from potential buyers for a stabilised product produced in a controlled way. Without



strict controls prices for a silage product would be the same as the fishmeal price above at €120. Reported prices in Norway are higher at approximately €200 per tonne for silage, but it is uncertain whether such prices would be achievable here given the volume of the fish silage market in Norway, synergies with the salmon industry and the well-developed transport logistics including the use of silage vessels which can transport large quantities of silage to the buyer.

The €80,000 equipment and installation cost is an average figure based on quotes from Norwegian companies and actual costs of similar units recently installed in the UK. Figure 3.1 below shows the layout of such a unit from a Norwegian company, Steinsvik. The cost for the system shown is approximately €65,000 but additional tanks for storing the silage would also be required.

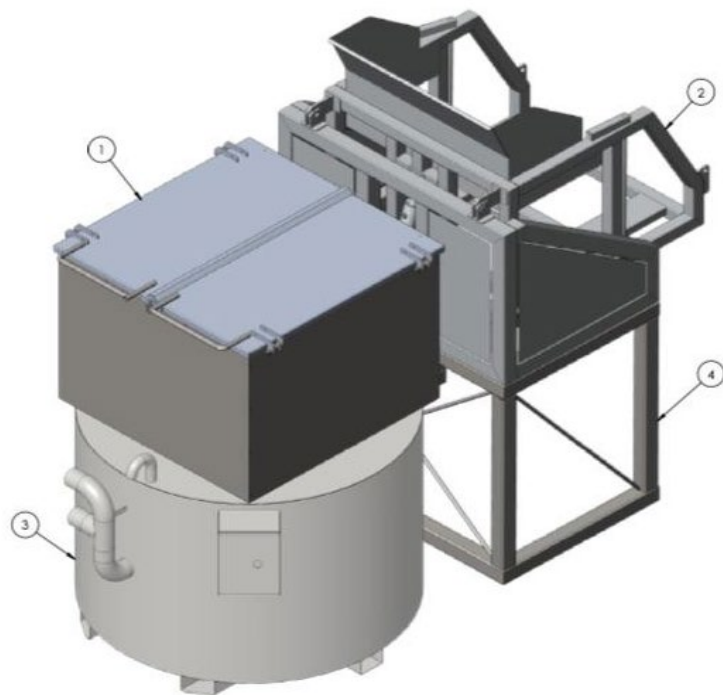

Figure 3.1: Primary silage unit from Stensvik in Norway. Secondary tanks for storing the prepared silage would also be required.

The projected return to fishermen for basic silage in Table 3.1 is the lowest of the five options, but there are some potential savings on transport and installation costs which are analysed further in the following chapter. The main advantage of the silage system is not necessarily that it attracts a better price but that when correctly operated the product is stabilised and protein degradation can be halted. The resulting silage could also be sold more locally as a protein supplement in animal feed and thus the transport cost could potentially be reduced.

Table 3.2 below shows a comparison between the potential returns per tonne of below MCRS fish with a tonne of round Whiting, round Haddock or small Plaice. The higher transport cost for small

Plaice reflects the fact that it is often necessary to transport small flatfish such as Plaice to continental markets such as Zeebrugge, where there is a greater demand for them.

Table 3.2: Costs and revenues per tonne of utilisation options for below MCRS fish in comparison to small Haddock, Whiting and Plaice.

| Economic variable | Fishmeal | Bait fresh | Bait frozen | Pet food | Silage basic | Round Whg/Had | Small Plaice |
|--|-------------|-------------|-------------|-------------|--------------|---------------|--------------|
| Transport | 45 | 30 | 30 | 45 | 45 | 45 | 120 |
| Labour | 10 | 20 | 25 | 10 | 20 | 10 | 10 |
| Boxing | 10 | 10 | 10 | 10 | 5 | 10 | 20 |
| Cold Storage | 0 | 10 | 120 | 10 | 0 | 0 | 0 |
| Plant Costs/tonne | 0 | 0 | 0 | 0 | 34 | 0 | 0 |
| Subtotal costs | 65 | 70 | 185 | 75 | 104 | 65 | 150 |
| Price per tonne from buyer | 120 | 250 | 250 | 130 | 140 | 1,100 | 900 |
| Net € return per tonne to fisherman | 55 | 180 | 65 | 55 | 36 | 1,035 | 750 |
| Loss Vs round fish per tonne | -980 | -855 | -970 | -980 | -999 | | |

Costs are based on 1 tonne units (25 X 40kg boxes) of below MCRS whitefish.

OPTIONS REQUIRING MORE SIGNIFICANT INVESTMENT OR LONGER TIME SCALES

A number of utilisation options exist which require more significant investment including more advanced processing of silage to produce concentrated silage (Fish Protein Concentrate, FPC) or hydrolysed fish protein (FPH).

FPC is a concentrated silage product that requires a combination of centrifuging, evaporation and pressing operations. Depending on the degree of processing applied the end-product can vary from a wet cake type product (essentially where liquid in the raw silage has been partially evaporated) to a virtually odourless and tasteless powder with a maximum total fat content of 0.75 per cent. The cost of processing increases with the degree of drying and fat separation required. The less processed products, which still have bone material mixed through are generally used in aquaculture and animal feed. The additional equipment required to move beyond raw silage production means that a minimum price for a first stage concentrated silage process which would include some evaporation is approximately €1,500,000. A Norwegian company, PG Flow systems, is selling an onboard advanced FPC silage production process for large freezer trawlers, which utilises recycled heat from the vessels main engine for heating and evaporation and which produces an advanced silage product without bone material. The system could be readily adapted for onshore operation also. The cost of the system is estimated at €5 to €7 million but the company claim that the silage product would have a

value of €1200 to €1500 per tonne compared to a raw silage value of €200 per tonne. Whether the high prices which FPC might achieve in Norway is possible in other countries is open to question. The FPC silage system in Table 3.3 illustrates the economic breakdown for such a system.

FPH is a stable product with good functional properties and high nutritional value, prepared from the protein fraction of whole fish or fish by-products by chemical or enzymatic hydrolysis. It is used mainly in animal feed but can also be used in the food industry. A pilot fish protein plant has been established recently in Ireland which is focussed on the production of FPH, Partly Hydrolysed Protein (PHP), fish bone powder and fish oil from Blue Whiting and Boarfish caught by large pelagic vessels. Although gadoids and other white fish, with their low oil content, are excellent candidates for the production of FPH one of the restrictions of using the fish protein plant is that it can only operate with raw fish frozen in blocks. The additional cost of freezing is reflected in the costs in Table 3.3. Whether the processing of below MCRS gadoid fish is a potentially viable option at this protein plant is uncertain but may be an avenue worth exploring further.

Another option would be for a group of co-ops or processors to set up and operate a small FPH plant. The costs indicated in Table 3.3 for such an operation are again for a small system capable of handling 10 tons per day which if run over 200 days would process 2,000 tons per year or approximately 55% of the total projected below MCRS gadoid landings. However as can be seen from Table 3.3 such a small system would be difficult to operate at a profit unless all of the revenue streams from the different products (FPH, Bone powder and oil) were maximised. The general problem that smaller systems are more difficult to make profitable applies in this case also. In interviews with a prospective small FPH system operator the difficulty of making a marginal business such as this profitable was discussed. In order to make a profit it is essential that valuable markets for all products of the FPH process; the FPH powder, fish oil and bone powder, would have to be found. Additionally, the plant should ideally be located in a landing port as protein degradation sets in very early. The interviewee was also unsure whether or not below MCRS fish would provide a sufficiently stable and high quality source of raw material in order to sell the products into high value markets.

The option to produce FPH powder of sufficient quality and under sufficiently hygienic conditions to produce food and cosmetic grade products would open up much higher potential markets, of approximately €20 per kg, but would also increase the plant investment requirements significantly.

A number of those who were interviewed mentioned that in more advanced processing such as FPC and FPH the equipment was not necessarily the greatest cost but that on an ongoing basis energy and labour costs were more significant.

The regional silage network option in Table 3.3 is based on a proposal made during one of the interviews that the fishmeal plant in Killybegs could organise a silage pickup and transport operation if some funding to install a number of silage units was available and if there was some certainty that a significant supply of below MCRS fish was available.



Additionally, the option of a small fishmeal plant based in the south of the country, which could be operated by a consortium of co-ops or processors, is included in order to examine the effect of reducing transport costs. The price included here is based on a quote from an Icelandic company for a small fishmeal plant with a capacity of 40 tons per day.

Discussions with operators and prospective operators of protein plants and equipment suppliers stressed that in common with the fish meal industry the fish protein industry is a marginal business dependent on both a reasonable level of scale and also successful marketing of multiple products arising from the process. As a result it is likely that any success in the FPH or FPC areas will depend on strong financial backing and time to develop the multiple markets necessary to maximise revenues. This may mean that Irish companies wishing to get involved in this area would require partners from countries where these industries are already developed in order to succeed.

The economic breakdown given in Table 3.3 does not claim to be the definitive statement on whether or not any of these options are viable or not. For example, the breakdown for the southern-based fishmeal plant would look very different if fish processing waste and pelagic fish were also included however that is beyond the scope of this study. Even smaller fishmeal units (under 10 tons per 24 hours) are available from some Icelandic and Norwegian companies but we have not analysed these as the advice from those companies is that it is not possible to make the smallest systems profitable on a stand-alone basis.

Table 3.3: Costs and revenues per tonne of below MCRS fish utilisation options requiring more advanced processing (Costs are based on 1 tonne units (25 X 40kg boxes) of below MCRS whitefish)

| Economic variable | Existing Protein Plant | FPC silage system | Silage FPH | Regional Silage Network | Small Fishmeal Plant |
|---|------------------------|------------------------|------------------------|-------------------------|------------------------|
| Transport | 45 | 20 | 20 | 20 | 25 |
| Labour | 25 | 40 | 40 | 20 | 10 |
| Boxing | 5 | 5 | 5 | 5 | 0 |
| Cold Storage | 65 | 0 | 0 | 0 | 0 |
| Plant installation cost | 0 | 5,000,000 ¹ | 3,000,000 ² | 0 | 3,000,000 ³ |
| Plant Costs/ton ⁴ | 0 | 500 | 300 | 0 | 300 |
| Energy requirement | Medium | High | High | Low | High |
| Subtotal costs | 140 | 565 | 365 | 45 | 335 |
| Price per tonne from buyer | 200 | 400 | 400 | 140 | 360 |
| € return per tonne to fisherman | 60 | -165 | 35 | 95 | 25 |
| Currently available to Irish whitefish industry | Possible | No | No | No | No |

¹The installation costs here are based on prices from a Norwegian company, PG Flow Solutions, for a system designed for use on board a fishing vessel but which can be adapted for onshore use. <https://pg-flowsolutions.com/portfolio/pg-silage-for-high-value-fpc/>

²Installation costs based on prices from prospective FPH plant operator.

³Installation costs based on quotes for small fishmeal plant (capacity 20 tons per day) from Norwegian and Icelandic companies.

⁴The costs per tonne above are based on an annual throughput in each case of 2,000 tons per year. This is a very small figure in comparison to the throughput values for most fishmeal plants but we use that figure to illustrate what the figures look like based purely on below MCRS fish landed due to the LO.

SCENARIOS

Scenarios could account for variables such as improvements in selectivity, quota-catch mismatch, compliance or changes in economic cost-base among others. An important factor also is likely to be time, as experiences from Norway and Iceland have shown that over time significant economic activity by companies specialising in high-value, niche products from viscera or other parts of fish can develop. Although such companies may not appear overnight their potential development in the context of long-term landings of unwanted catches will be considered in our analysis.

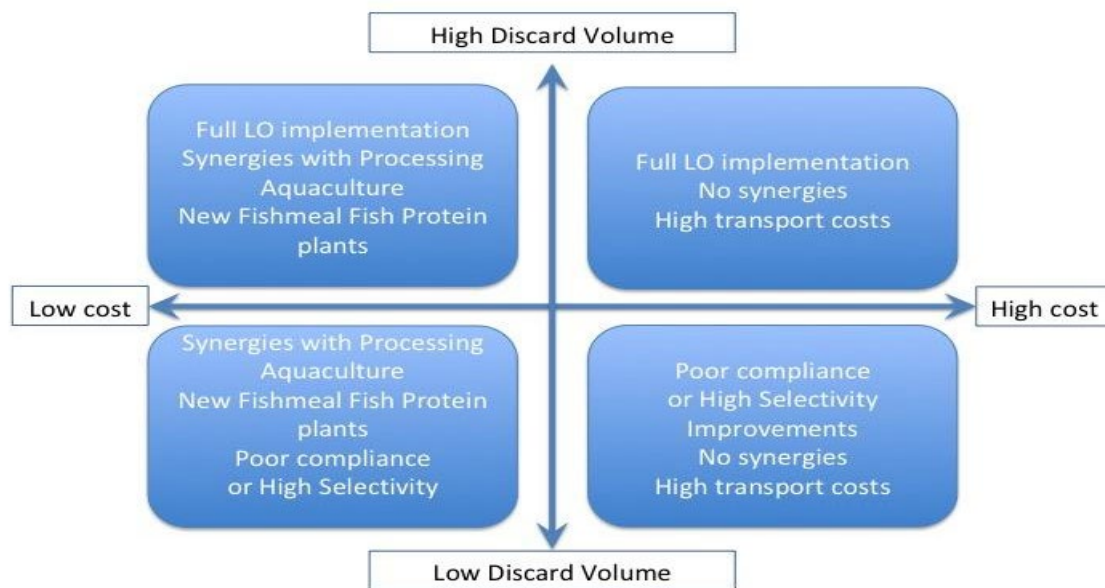

Figure 3.2: Scenarios likely to affect discard volumes and associated costs

Equipment costs shown in Table 3.3 for new protein or fishmeal plants are for relatively small units. An even smaller €1 million plant with a daily capacity of less than 10 tons is available from the Icelandic company Hedinn (<https://hedinn.com/fishmeal-processing/>). However, even according to the manufacturing company it is impossible to make a unit like this profitable on a stand-alone basis. It would only work as part of a larger processing operation, with associated cost efficiencies and synergies particularly regarding labour and energy. For that reason, we have used slightly larger units with a somewhat higher installation cost but even at that size some of the difficulties in making a stand-alone unit profitable exist.

CONSEQUENCES OF REDUCTION IN VOLUMES OF DISCARDS.

A decrease in discard volumes, either due to non-compliance or improved selectivity, would not have an overly negative impact on existing options such as the use of the fish meal plant in Killybegs.

However, it would have a significant effect on any business plans which require even low levels of investment. Options that are marginal in a high-volume scenario will become unfeasible without significant moves towards higher value products and markets. This highlights a structural problem with the LO when it comes to the disposal of small fish as their quantities should theoretically decrease over time therefore compromising the incentive for investment in market based solutions.

However, where a decrease in discard volumes occurs due to selectivity improvements, the negative impact of reduced volumes on processing options ashore would be offset by more profitable and selective fishing activities and an associated improvement in efficiency of quota use. This can be clearly seen when comparing the value of round fish above MCRS with the best available values for below MCRS fish. Table 3.4 demonstrates that a fisherman would have to land at best 6 tons of below MCRS fish to receive the same economic return as 1 tonne of round fish above MCRS and at worst 29 tons.

Table 3.4: Equivalent number of tons required for various utilisation options to equal value of Round Whiting/Haddock and small Plaice.

| Economic variable | Fishmeal | Bait fresh | Bait frozen | Pet food | Silage basic | Round Whg/Had | Small Plaice |
|---|-----------|------------|-------------|-----------|--------------|---------------|--------------|
| Subtotal costs | 65 | 70 | 185 | 75 | 104 | 65 | 150 |
| Price per ton from buyer | 120 | 250 | 250 | 130 | 140 | 1,100 | 900 |
| Net € return per ton to fisherman | 55 | 180 | 65 | 55 | 36 | 1,035 | 750 |
| Tons required to equal value of 1 ton roundfish | 19 | 6 | 16 | 19 | 29 | | |
| Tons required to equal value of 1 ton small plaice | 14 | 4 | 12 | 14 | 21 | | |

COST REDUCTION

The main costs associated with unwanted catch utilisation are initially infrastructure costs and on an ongoing basis transport, labour and energy costs. The issue of reducing initial infrastructure costs by looking at the economics of small processing units is complicated by the fact that small units are more difficult to make profits from in a marginal industry. The Regional Silage Network option in Table 3.3 is based on reduced transport costs arising from a partnership with the buyer and reduced infrastructure costs if funding to install silage units can be sourced. This scenario could be the only potential way in the medium term that an improvement in returns to fishermen could be achieved over and above the currently available options of bait, fishmeal or pet food. Whether the



circumstances required for such a scenario, in particular the necessity for a stable and significant raw material supply, are realistic is not certain at this point however.

Achieving cost reductions through synergies with other processing operations is possible. There are one or two caveats to how this can be achieved however. Buyers from multiple sectors continually stressed the fact that the more mixing of species and species types that occurred the lower the price of the product would be.

CONCLUSIONS

In this section we summarise the best options for the utilisation of unwanted catch in Ireland in the short and medium term and the most relevant issues which may positively or negatively impact on those options. The most important challenge we address is which uses could provide an economic return to Irish fishermen landing unwanted catches and thus incentivise compliance with the LO. We conclude with some points about which criteria are most likely to create the right conditions for an economically feasible utilisation option.

The first point is that there are no “magic bullet” solutions which can produce high economic returns to fishermen for size classes of fish which previously had no economic value. Returns will be in most cases a fraction of the value that smaller grades of above minimum size fish can achieve.

One of the implications of this finding is that concern that the LO, by requiring fishermen to land small fish, would result in the targeting of undersize and juvenile fish is unfounded. At least in the case of Ireland there is no possibility of this occurring under current conditions. Unfortunately, this also implies that there are not significant economic incentives to comply with the LO in the sense that compliance means the landing of small fish. Quota Uplift, the raising of quotas to account for fish that was previously discarded should address at least some of this economic losses issue.

The second implication and the flipside of the first, is that there is a huge incentive to fish more selectively and, as far as possible to utilise the quota available in the most economically rational manner. The landing of below MCRS fish will lead to the loss of a large part of the future economic value in those fish. The values we have calculated for currently available options show that 1 tonne of above MCRS fish is worth between 6 and 19 times the value of 1 tonne of below MCRS fish.

Selectivity improvements alone cannot resolve all LO issues however and some residual unwanted catches will always be an issue in most demersal fisheries. In such cases the best current utilisation option appears to be the pot fishery bait market. When averaging between fresh and frozen supplies to this market a value of €100 to €120 per tonne could be returned to the fisherman for below MCRS fish landed. While significant investment in advanced equipment is not required for this option the main infrastructural constraint here is access to refrigerated and frozen storage. This issue has been successfully addressed by a number of co-ops and sales agents who have received EMFF funding from BIM to improve storage infrastructure. Even in upgraded facilities at certain times when large volumes of commercial landings are present there would still be competition for space in refrigerated storage.

The next best currently available utilisation options are fishmeal, which can essentially take an unlimited supply, and pet food which can take more limited quantities. Both options would deliver a price per tonne to fishermen of approximately €50 per tonne. This highlights the fact that the price differential in demersal fish between small size grades of fish sold on the fresh market and fishmeal is far higher than it is for pelagic fish which is why the fishmeal option is only used occasionally for



demersal fish. The prices achievable in the fishmeal option are essentially fixed as fishmeal is a global commodity and significant improvements on that price are highly unlikely.

In the pet food option there may be opportunities to improve prices to a level above that outlined in our initial analysis. Conversations with pet food company operators and Enterprise Ireland experts in the area have highlighted that there is a growing market for high quality niche pet food products from whole fish or fish-based ingredients. In common with any other potentially promising options the requirement would be for a reasonably stable and significant supply of good quality fish with as little mixing of species as possible. The high value pet food market is an option that is worth exploring further.

A potential option, which is being discussed throughout Europe, is the use of small silage units to stabilise unwanted catches either at sea or ashore before distributing the product to fishmeal plants or other buyers. The difficulty with this option is that it does not add significant value to the product without further concentration and concentration requires more significant investment in equipment. The main advantage of the basic silage process is that it prevents further degradation of the product and allows for the accumulation of silage until a full transport load is ready and thereby reduces transport costs. A network of regional silage units, partly funded by EMFF or other funding, with a partnership arrangement for transport with a fishmeal plant or other buyer and fed by a significant supply of raw material would have some potential to reduce costs and deliver a reasonable return to fishermen.

In the medium term there are a number of options that would require more significant investment but could potentially deliver higher value products. A common problem across almost all of these options is that there is a conflict between the investments required, their high supply volume nature, and the policy goal of the LO, which is to reduce the supply of undersized fish. The fact that to date only very small volumes of below MCRS catches have been landed throughout Europe adds to the unattractive nature of these options for investors, at least currently. One exception to this is the possibility that a supply of gadoid fish could potentially be block frozen and processed through the new fish protein plant in the North West of the country. The technical details and economic viability of this would have to be worked out but it is an option worth exploring as potentially there could be a high value market available for the products of this process.

In the long term what should be aimed at, in line with the desired goal of the LO to reduce unwanted catches, is high value uses of smaller volumes of below MCRS fish which cannot be avoided. This calls into question any business plans and large infrastructural investments based solely on discards. Viable options would have to be established in conjunction with existing processing operations and existing supply lines of processing waste or low value commercial grades of fish.

To summarise in order to successfully add value to unwanted catches in the longer term it appears that most if not all of the following criteria should be met:



- Prospective operators would have to be confident that a reasonable supply of smaller fish will be available in the first place.
- Prospective plants should ideally be in, or at least in close proximity to, a fishing port where significant landings will occur as protein degradation in fish occurs quickly.
- Synergies with other fish processing activities are essential in particular regarding energy recycling and labour.
- A long-term approach will have to be taken by any prospective operator. Experiences from Norway and Iceland have shown that over time significant economic activity by companies specialising in high-value, niche products from viscera or other parts of fish will not appear overnight but develop over time.
- The financial clout and long-term commitment required means that either a large co-operative or consortium would be necessary in order to sustain the enterprise.
- It will be necessary to fully exploit high value niche markets for all product streams in order to get the most value from the raw material. For example, a fish protein (FPH) operation could target pharmaceutical products or human functional foods at the higher level, performance proteins for high-end animal feed at the middle level and high-quality fertiliser at the lower level. A successful example of this approach is the case of Celtic Sea Minerals, based in Castletownbere, which has gradually, through investment in R&D, increased the niche value of its products over time.
- Achieving this will require significant technical and marketing expertise and a commitment to R&D.
- Companies in other countries with a history of bycatch and by-product utilisation have built up significant expertise in both the technical aspects of these processes and in the marketing of the final products so a partnership approach with such companies would be advisable.



REFERENCES

Balazuc A., Goffier E., Soulet E., Rochet M.J., Leleu K., 2016. EODE – Expérimentation de l’Obligation de DEbarquement à bord de chalutiers de fond artisans de Manche Est et mer du Nord, et essais de valorisation des captures non désirées sous quotas communautaires. ^[1]_[SEP]136 + 53 pp.

BIM, 2015. The Business of Seafood report 2015 pp 21.

BIM, 2016. The Business of Seafood report 2016 pp 36.

Catchpole, T., Elliott, S., Peach, D. and Mangi, S. (2014). Final report: The English discard ban trial. Cefas report. ^[1]_[SEP]

Directorate of Fisheries. (20. September 2017b). *Úthlutað aflamark*. Sótt frá www.fiskistofa.is: <http://www.fiskistofa.is/fiskveidistjorn/stjornfiskveida>

Directorate of fisheries. (20. September 2017a). *Um fiskveiðistjórnun*. Sótt frá www.fiskistofa.is: <http://www.fiskistofa.is/fiskveidistjorn/stjornfiskveida>

EC. 1998. European Council Regulation No 850/98 of 30 March 1998 for the conservation of fishery resources through technical measures for the protection of juveniles of marine organisms. (OJ L 125, 27.4.1998).

EC. (2007). *Impact assessment of discard polic for specific fisheries*. Brussels: EC.

EU. (2016). *Facts and figures on the common fisheries policy: basic statistical data 2016 edition*. Brussels: EU.

European Commission. 2017. Communication from the Commission on the State of Play of the Common Fisheries Policy and Consultation on the Fishing Opportunities for 2018. COM(2017) 368 final. <http://eur-lex.europa.eu/legal-content/EN/TXT/PDF/?uri=CELEX:52017DC0368&from=EN>

European Commission. 2018. Towards New SCIPS: Advisory Council Consultation. Working document of the European Commission. 4 pp.

FiskerForum. (13. July 2017). *Ensilering kan gore bifangsten færdirfuld*. Sótt frá www.fiskerforum.dk: <http://www.fiskerforum.dk/erhvervsnyt/a/ensilering-kan-goere-bifangsten-vaerdifuld-13072017>

Fitzpatrick, M., and Nielsen, K.N. 2016. DiscardLess Policy Brief No1: Year 1 of the Landing Obligation, key issues from the Baltic and Pelagic fisheries, 30 Sept 2016, <http://dx.doi.org/10.5281/zenodo.215155>

Graham, N., Ferro, R., Karp, W., & MacMullen, P. (2007). Fishing practice, gear design and the ecosystem approach - three case studies demonstrating the effect of management strategy on gear selectivity and discards. *Journal of marine Science* , 744-750.



Hedley, Christopher and Catchpole, Tom. 2015. The Landing Obligation and its Implications on the Control of Fisheries. European Parliament Fisheries Committee Report IP/B/PECH/IC/2014_20.

ICES. (2017). *Cod (Gadus morhua) in subareas 1 and 2 (Norwegian coastal waters cod)*. Copenhagen: ICES.

Islandsbanki. (2016). *Íslenskur sjávarútvegur*. Reykjavík: Islandsbanki.

Mangi, S. C., and Catchpole, T. L. 2014. Using discards not destined for human consumption. *Environmental Conservation*, 41: 290-301. ^[1]

Marine Institute, 2011. Atlas of Demersal Discarding: Scientific Observations and Potential Solutions. pp 93.

Nautilus Consultants, 2003. Disposal and Re-utilisation of fish and fish processing waste. Report prepared for the Marine Institute. pp138.

Pálsson, P. (17. January 2013). *Hugmyndir um að auka verðmæti þorsks um 135 milljarða króna*. Sótt frá www.mbl.is: <http://www.mbl.is/greinasafn/grein/1451482/>

PG Flow Solutions, 2017. Silage system on board fishing vessels: exploiting the full potential of white fish. <https://pg-flowsolutions.com/portfolio/pg-silage-for-high-value-fpc/>

Richardsen, R., Nystöyl, R., Strandheim, G., & Marthinussen, A. (2016). *Analyse marint restråstoff 2015*. Trondheim: Sintef.

Seafish, 2005. Strategic framework for seafood waste management. Report ref: SR574.

SDSP. (2015). *Spanish Discard Sampling Program*. ES: SDSP.

Shahidi, F., & Barrow, C. (2007). *Marine Nutraceuticals and functional foods*. London: Taylor & Francis Group.

Sigurðsson, G., Pálsson, Ó., Björnsson, H., Hólmgeirsdóttir, Á., Guðmundsson, S., & Ottesen, Þ. (2016). *Mælingar á brottkasti þorsks og ýsu 2014-2015*. Reykjavík: Marine & freshwater research institute.

Statistics Norway. (2017, September 30). *Fisheries, 2016, preliminary figures*. From www.ssb.no: <https://www.ssb.no/en/jord-skog-jakt-og-fiskeri/statistikker/fiskeri/aar-forelopipe/2017-01-12?fane=tabell&sort=nummer&tabell=290273>

STECF. (2014, September 21). *STECF 14-20 Fishing effort regimes data tables*. From STECF: <https://stecf.jrc.ec.europa.eu/data-reports>

STECF database FDI data call 2017: landings and discards. <https://stecf.jrc.ec.europa.eu/dd/effort/graphs-annex>

STECF, Håkansson, K. B., & Ulrich, C. (2015, August 21). Data extracted from STECF datasets and aggregated and expanded on by DTU. Copenhagen, Denmark.



Tegen Mor Consultants (2015). Potential Implications of the Landing Obligation on Onshore Seafood Supply Chains in the UK. Report commissioned by Sea Fish Industry Authority, UK.

Viðarsson, Jonas R., Þorlákur Guðjónsson, Sigríður Sigurðardóttir. 2015. Report on current practices in the handling of unavoidable, unwanted catches. DiscardLess D5.1.

Viðarsson, Jónas R., Marvin I. Einarsson and Sigurður Ö. Ragnarsson. 2016. Report containing identification and recommendations on innovative, applicable and practical solutions for on-board handling of unavoidable unwanted catches. DiscardLess D5.2.

Viðarsson, Jónas R., Bruno Iñarra, Begoña Pérez-Villarreal and Erling Larsen. 2016. Diagnosis of the inventory of the generated unavoidable unwanted catch. DiscardLess D6.1.